



HOONLY INTERNATIONAL CO., LTD

Aluminium Profile | Accessories | Aluminium Die-casting | Custom Shapes

2017 Edition

HOONLY INTERNATIONAL
Aluminum Ceiling System



Products Manuals

Aluminum Ceiling System

Anyang Hoonly International Co.,Ltd

Address: No.201, Tongle Community Building,
Fanglin Rd, Anyang, Henan, China

Tel: +86 372 6885238

Fax: +86 372 6885238

E-Mail: [Hello@hoonly.com](mailto>Hello@hoonly.com)

Sales@hoonly.com

[Https://haluminium.com](https://haluminium.com)



工程案例
ENGINEERING
case

天花管 / 方管系列
CEILING TUBE
Square tube series

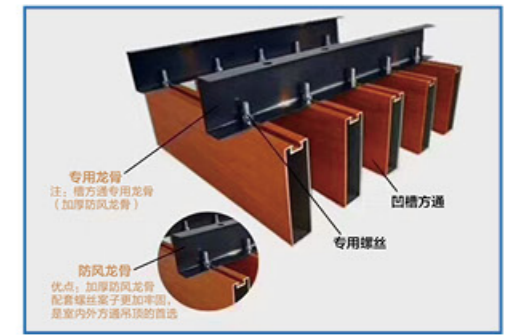



天花管 / 方管系列
CEILING TUBE
 Square tube series



工程案例
ENGINEERING
 case

天花板吊顶又称顶棚，天花板，是建筑装饰工程的一个重要子分部工程，天花板吊顶具有保温、隔热、隔声、弥补房屋本身的缺陷、增加空间的层次感、便于补充光源、便于清洁、吸声的作用，也是电气、通风空调、通信和防火，报警管线设备等工程的隐蔽层。过去传统民居中多以草席、苇席、木板等为主要材料，随着科技的进步更多的现代建筑材料被应用进来。

Ceiling is also called the roof, ceiling, is an important sub division of architectural decoration project engineering, ceiling with heat preservation, heat insulation, sound insulation, make up the defects of the house itself, increased administrative levels feeling of the space, is advantageous for the additional light source, easy to clean, sound-absorbing effect, and electrical, ventilation, air conditioning, communication and fire prevention, alarm equipment, such as pipeline project of the hidden layer. In the past, straw MATS, reed MATS and wooden boards were the main materials in traditional dwellings. With the progress of science and technology, more modern building materials were applied.



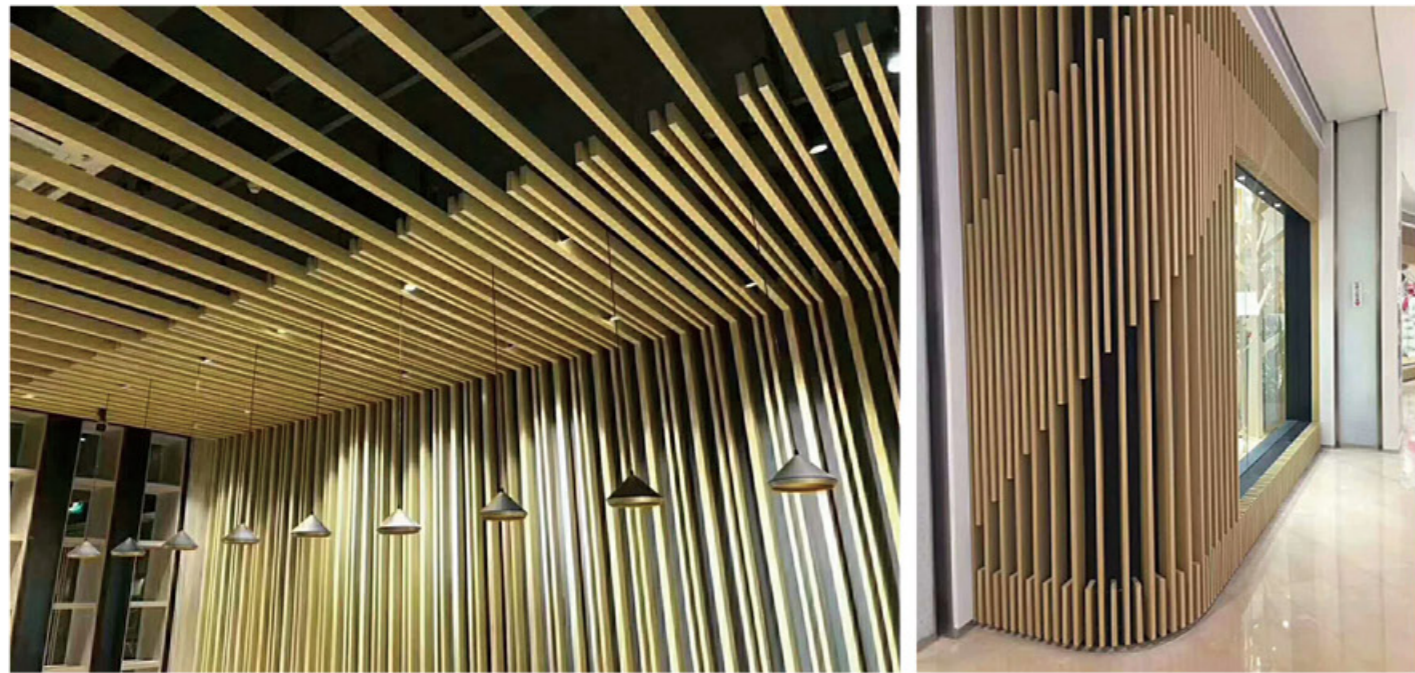

工程案例 ENGINEERING case

产品特性

1. 分割空间。吊顶是分割空间的手段之一，通过吊顶，可以使原来层高相同的两个相连的空间变得高低不一，从而划分出两个不同的区域。如客厅与餐厅，通过吊顶分割，即使两部分分工明确，又使下部空间保持连贯、通透，一举两得。
2. 吊顶可以将许多管线隐藏，还可以预留灯具安装部位，能产生点光、线光、面光相互辉映的光照效果，使室内增色不少。
3. 增强装饰效果。天花板吊顶作用可以丰富顶面造型，增强视觉感染力，使顶面处理富有个性，从而体现独特的装饰风格
4. 隔热保温。顶楼的住宅如无隔热层，夏季时阳光直射房顶，室内如同蒸笼一般，可以通过吊顶加一个隔热层，起到隔热降温的功用。冬天，它又成了一个保温层，使室内的热量不易通过屋顶流失。
5. 便于清洁。厨房和卫生间同属于是水汽、油烟居多的地点，天花板吊顶不但可以防止水汽进入房顶还可以防止油烟散乱，由于便于天花板吊顶属于金属制成的，所以便于清洁。

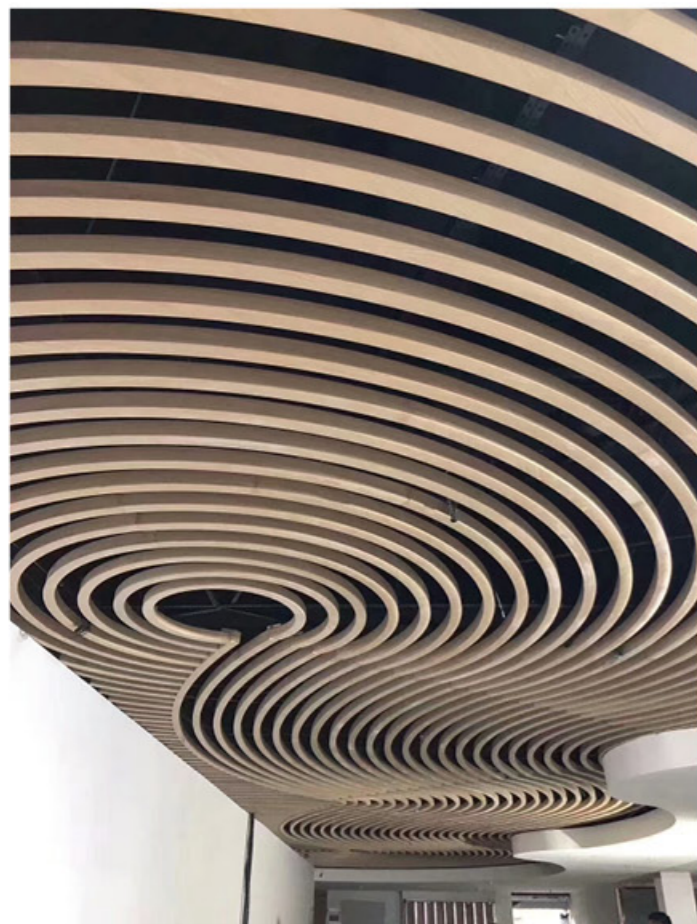

Optional color

可选颜色



9A23



9A24



9A03



9A04



9A05



9A06



9A08



9A09



9A10



9A11



9A12



9A13



9A14



9A15



9A16

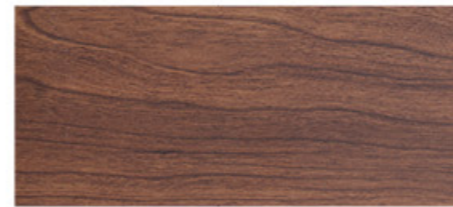

9A17



9A18



9A19



9A20



9A22



9A21

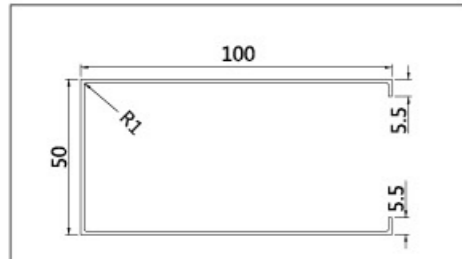

名称: 50x100UC
壁厚: 0.8 0.9 1.1 1.4mm

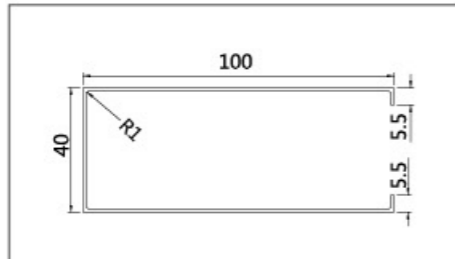

名称: 40x100UC
壁厚: 0.8 0.9 1.1 1.4mm

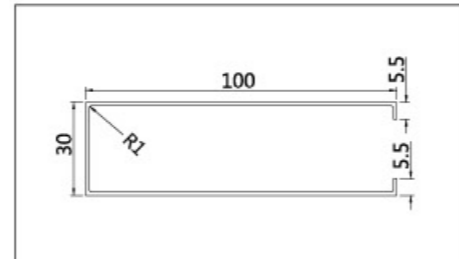

名称: 30x100UC
壁厚: 0.8 0.9 1.1 1.3mm

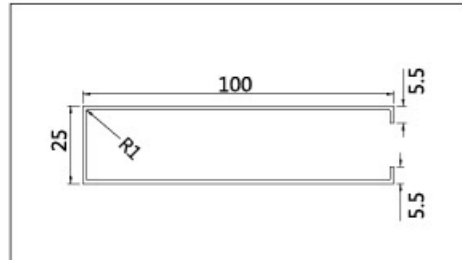

名称: 25x100UC
壁厚: 0.7 0.8 0.9 1.1 1.3mm

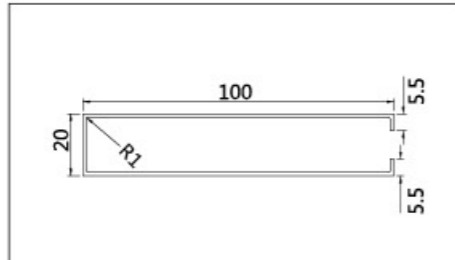

名称: 20x100UC
壁厚: 0.7 0.8 0.9 1.1 1.3mm

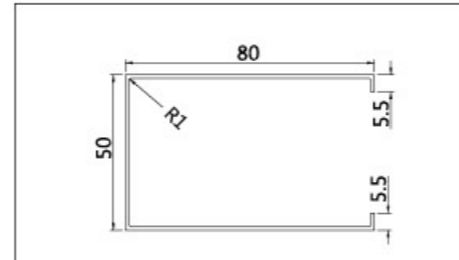

名称: 50x80UC
壁厚: 0.7 0.8 1.1 1.3mm

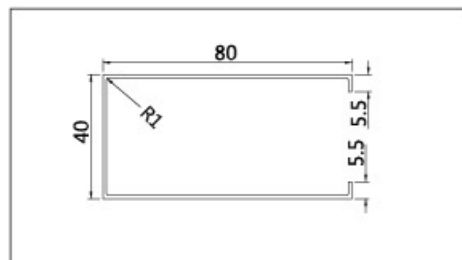

名称: 40x80UC
壁厚: 0.7 0.8 0.9 mm

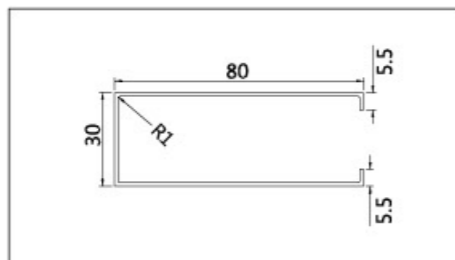

名称: 30x80UC
壁厚: 0.7 0.8 0.9 mm

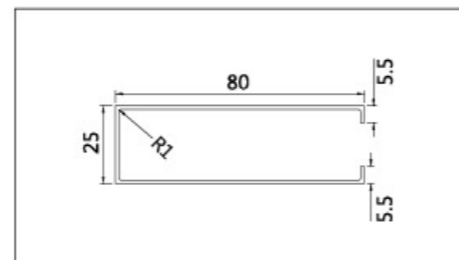

名称: 25x80UC
壁厚: 0.6 0.7 0.8mm

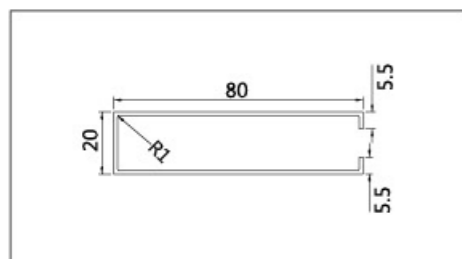

名称: 20x80UC
壁厚: 0.7 0.8 0.9 mm

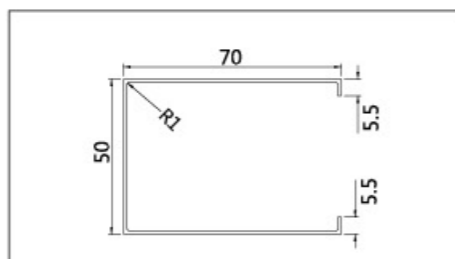

名称: 50x70UC
壁厚: 0.7 0.8 0.9 mm

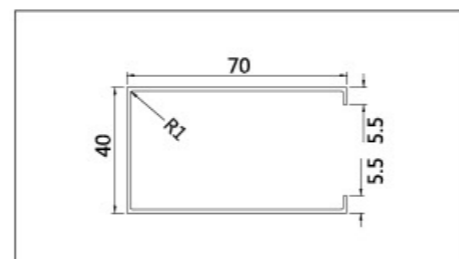

名称: 40x70UC
壁厚: 0.7 0.8 0.9 mm

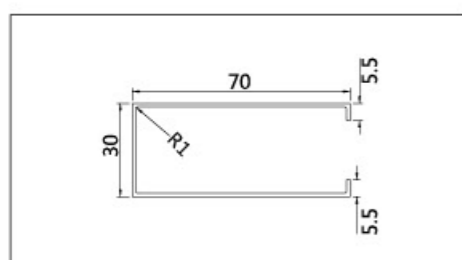

名称: 30x70UC
壁厚: 0.7 0.8 0.9 mm

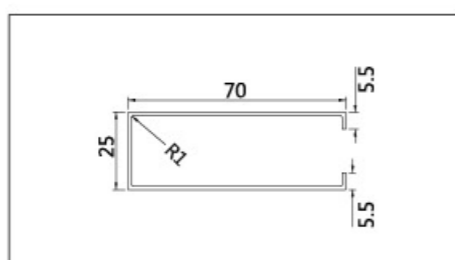

名称: 25x70UC
壁厚: 0.7 0.8 0.9 mm

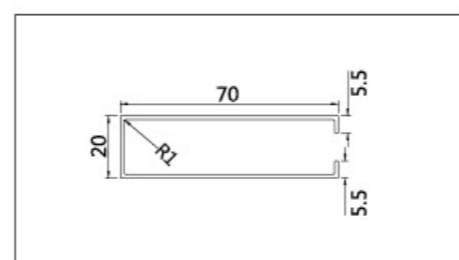

名称: 20x70UC
壁厚: 0.7 0.8 0.9 mm

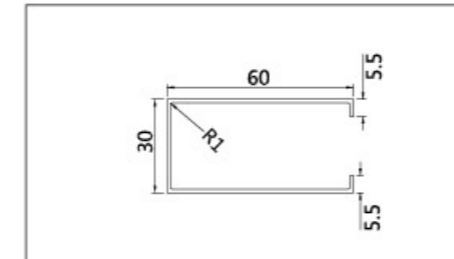

名称: 30x60UC
壁厚: 0.6 0.7 0.9 mm

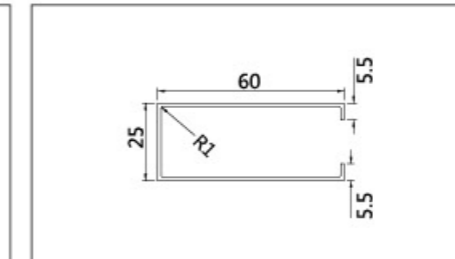

名称: 25x60UC
壁厚: 0.6 0.7 0.9 mm

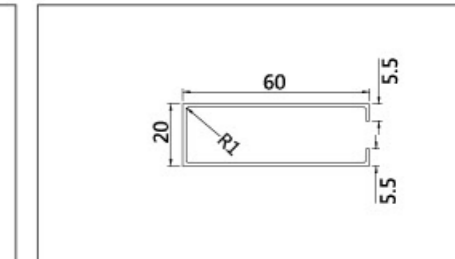

名称: 20x60UC
壁厚: 0.6 0.7 0.9 mm

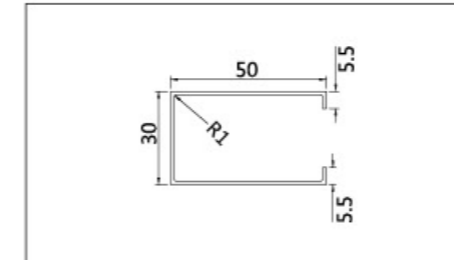

名称: 30x50UC
壁厚: 0.6 0.7 0.9 mm

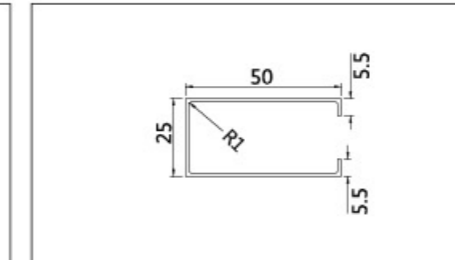

名称: 25x50UC
壁厚: 0.6 0.7 0.9 mm

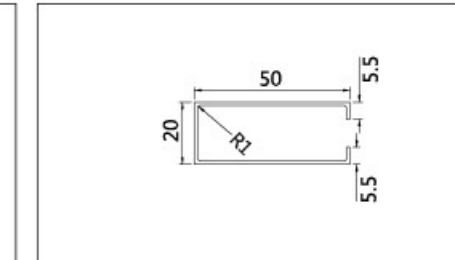

名称: 20x50UC
壁厚: 0.6 0.7 0.9 mm

schematic diagram
of ceiling installation
天花安装示意图

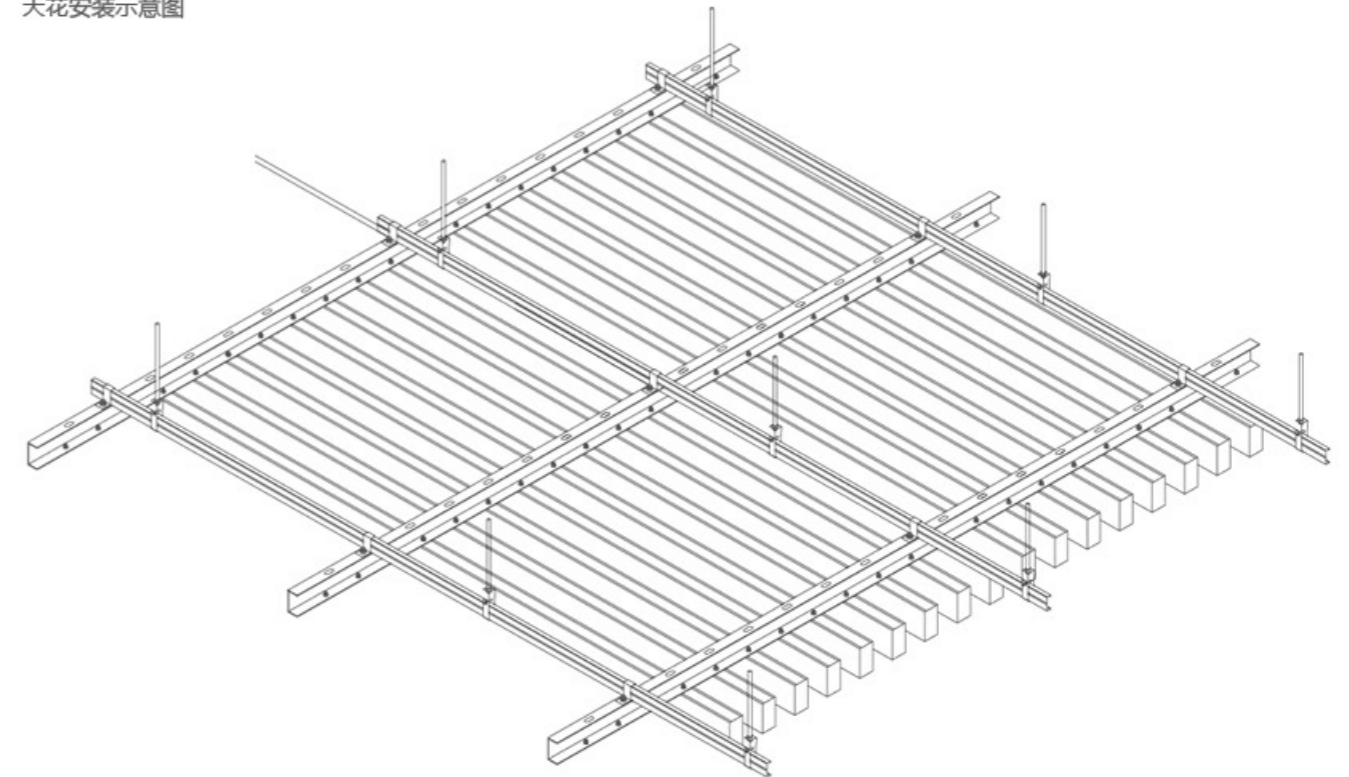

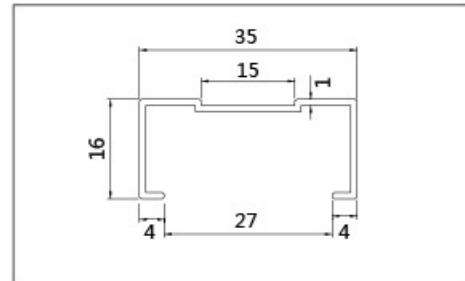

名称: 35x16 加强筋
壁厚: 1.0 1.2 1.4mm

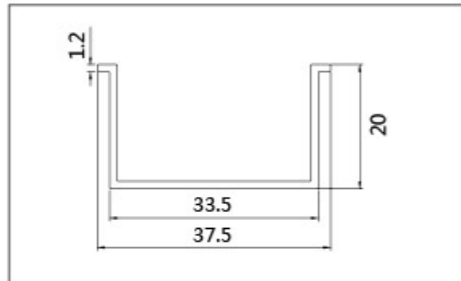

名称: 37.5x20 加强筋 - 周
壁厚: 1.2mm

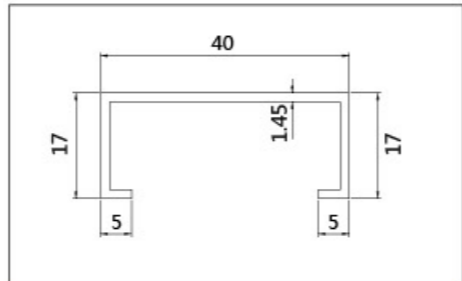

名称: 40x17 加强筋
壁厚: 1.45mm

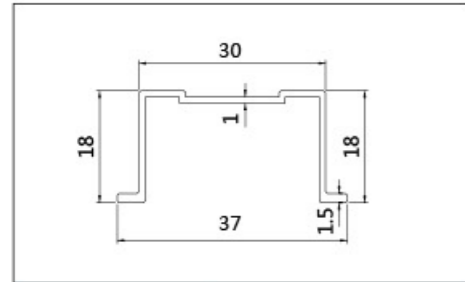

名称: 37x18 加强筋
壁厚: 1.0mm

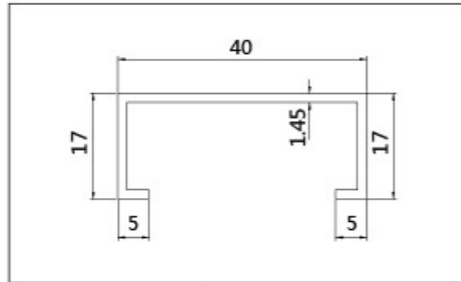

名称: 40x17 加强筋
壁厚: 1.45mm

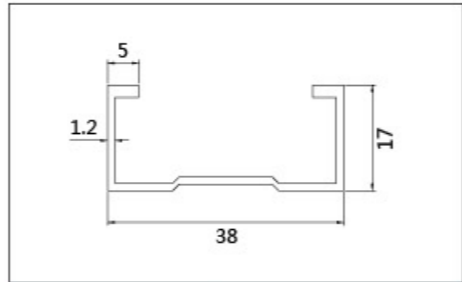

名称: 38x17 加强筋
壁厚: 1.2mm

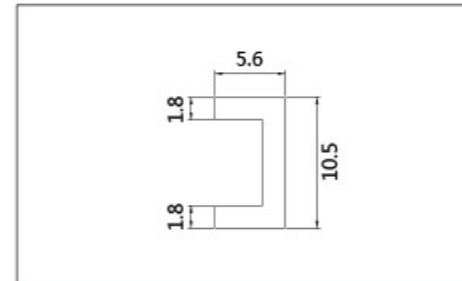

名称: CD-0803
壁厚: 2.0mm

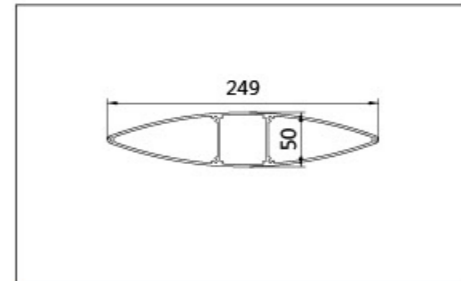

名称: CD-1265
壁厚: 2.2mm

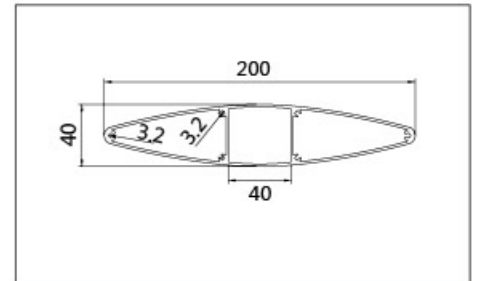

名称: CD-1221
壁厚: 1.7mm

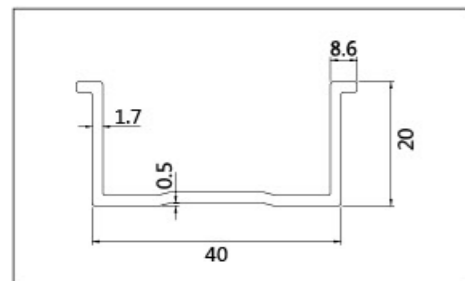

名称: 40x20 加强筋
壁厚: 1.7mm

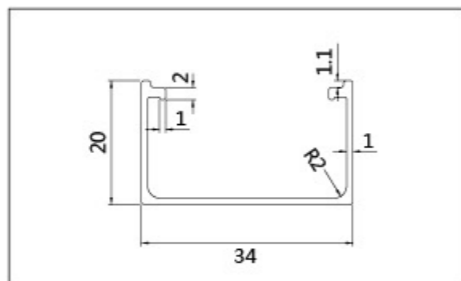

名称: 34x20 加强筋
壁厚: 1.0mm

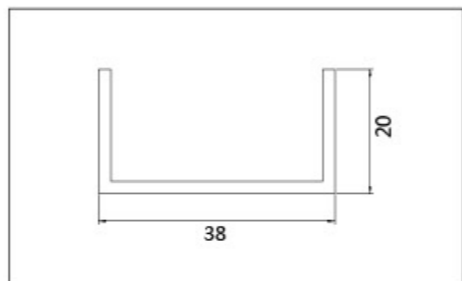

名称: 20x38U
壁厚: 2.0mm

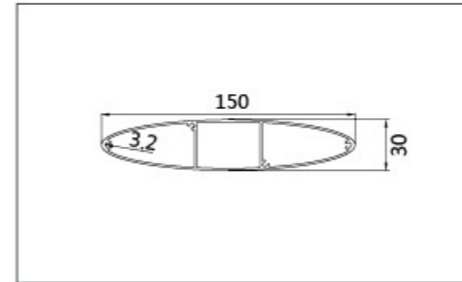

名称: 150x30x1.2
壁厚: 1.2mm

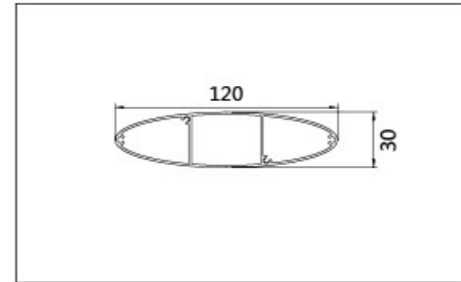

名称: 120x30x1.2
壁厚: 1.2mm

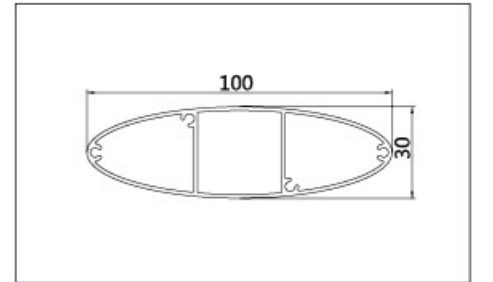

名称: 100x30x1.2
壁厚: 1.2mm

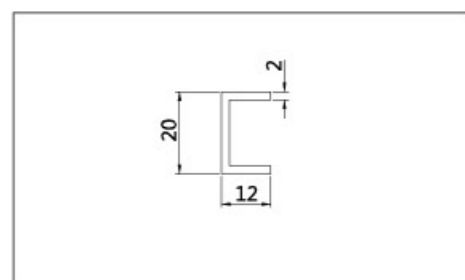

名称: CD-1255
壁厚: 2.0mm

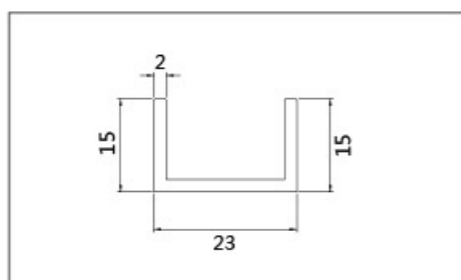

名称: CD-1217
壁厚: 2.0mm

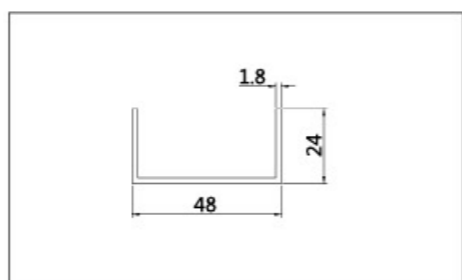

名称: 48x24U 槽
壁厚: 1.8mm

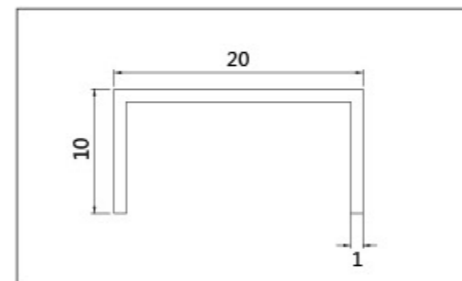

名称: CD-0801
壁厚: 1.0mm

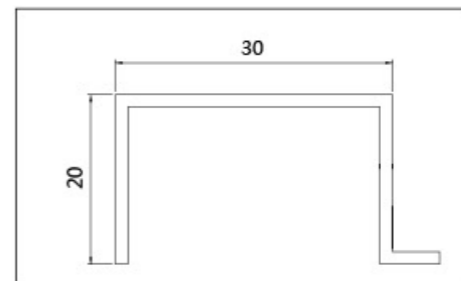

名称: CD-0802
壁厚: 1.0mm

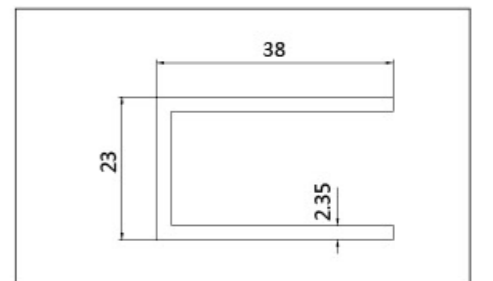

名称: CD-0828
壁厚: 2.35mm

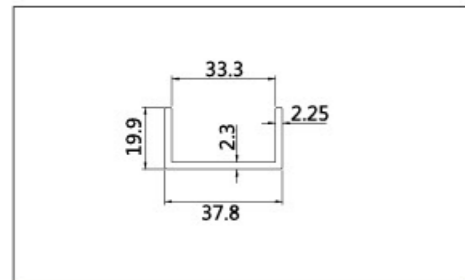

名称: CD-0978
壁厚: 2.25mm

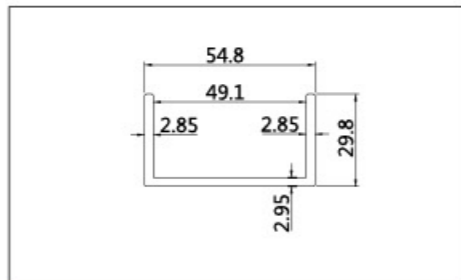

名称: CD-0979
壁厚: 2.85mm

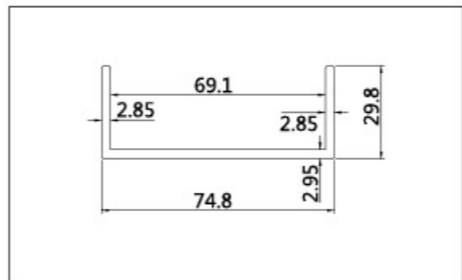

名称: CD-0980
壁厚: 1.6mm

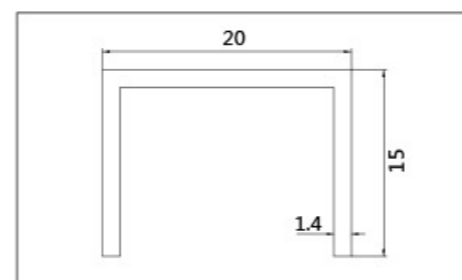

名称: CD-0886
壁厚: 1.4mm

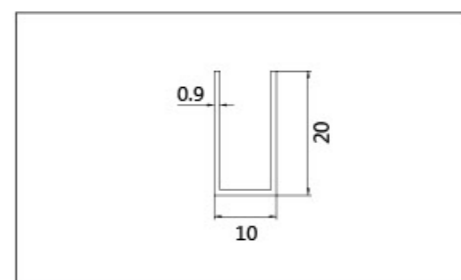

名称: CD-0931
壁厚: 0.9mm

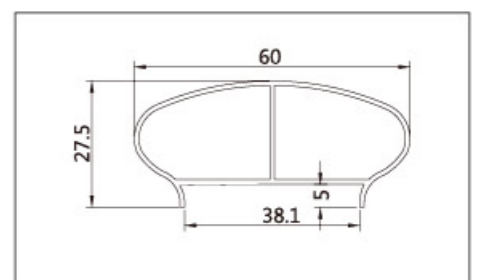

名称: 1191
壁厚: 2.0mm

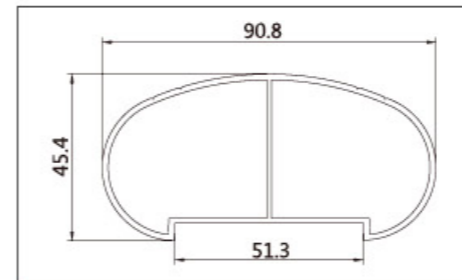

名称: 1152
壁厚: 1.6mm

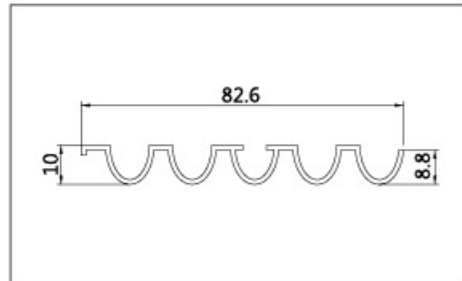

名称: CD-0256
壁厚: 1.2mm

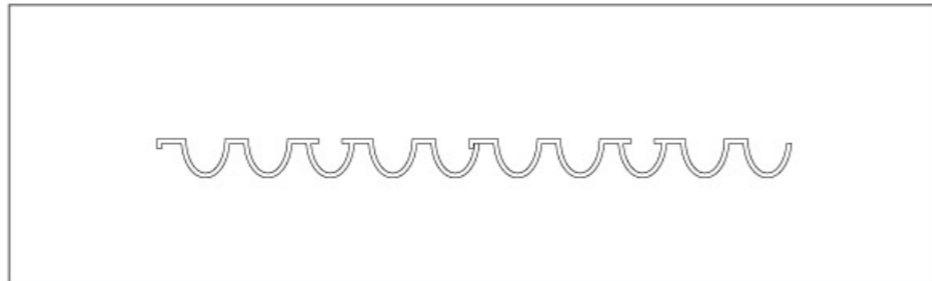

装配图

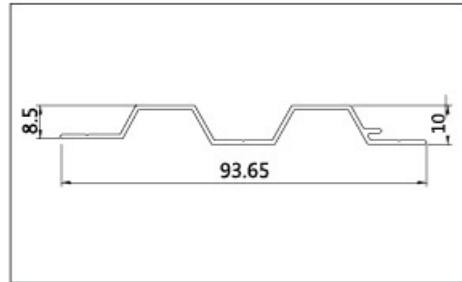

名称: CD-0261
壁厚: 1.1mm

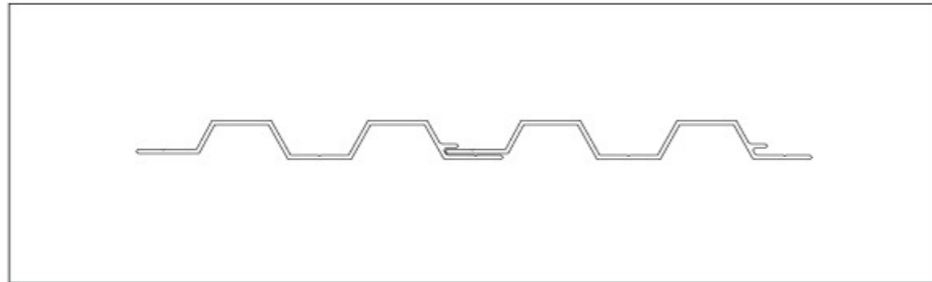

装配图

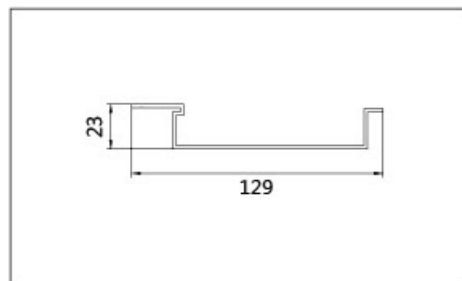

名称: CD-1386
壁厚: 1.8mm

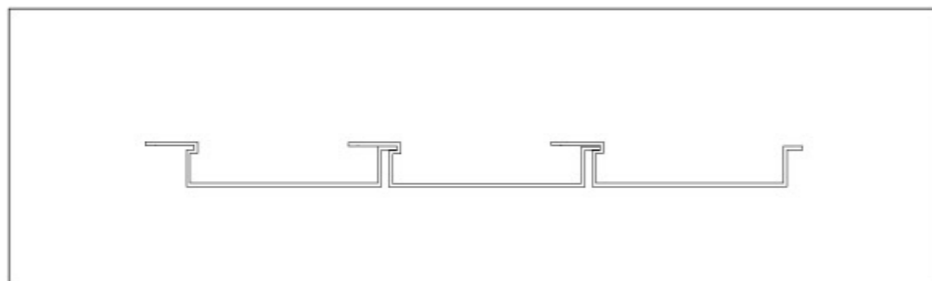

装配图

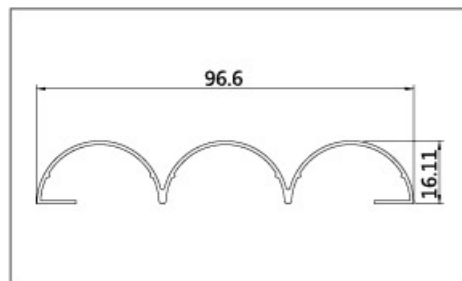

名称: CD-0716
壁厚: 0.9mm

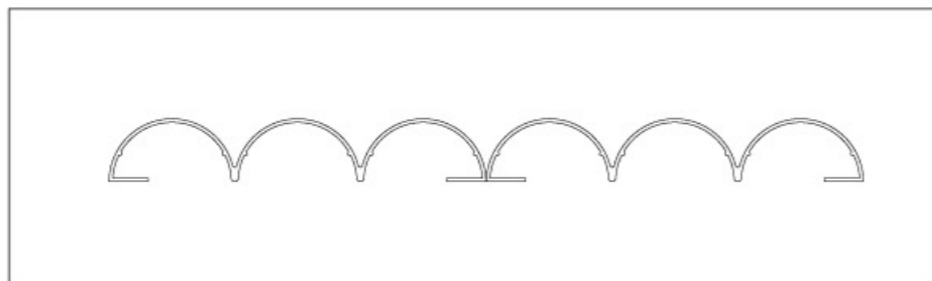

装配图

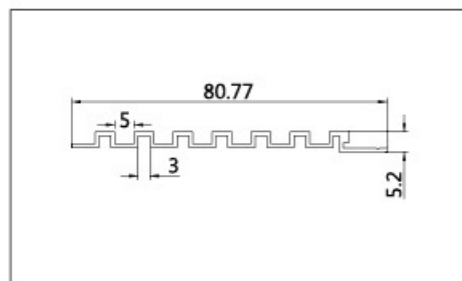

名称: CD-02847
壁厚: 1.0mm

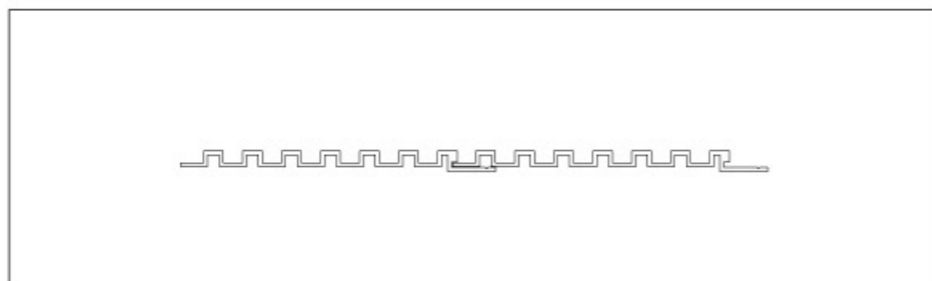

装配图

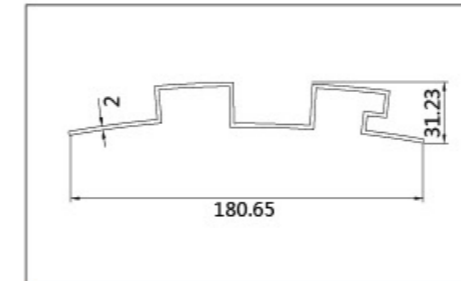

名称: CD-1045
壁厚: 2.0mm

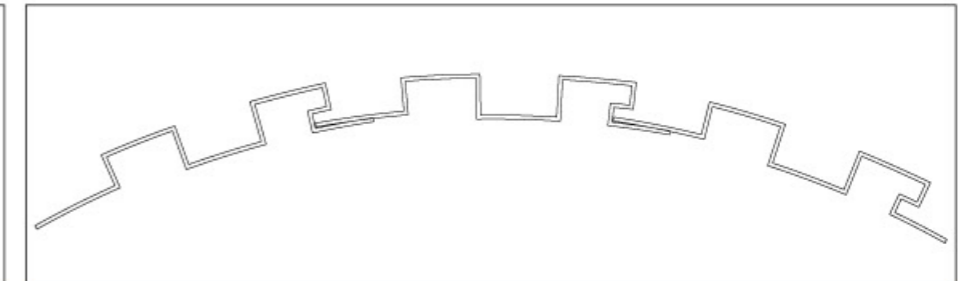

装配图

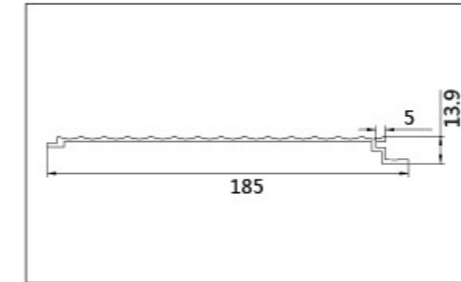

名称: CD-1049
壁厚: 2.0mm

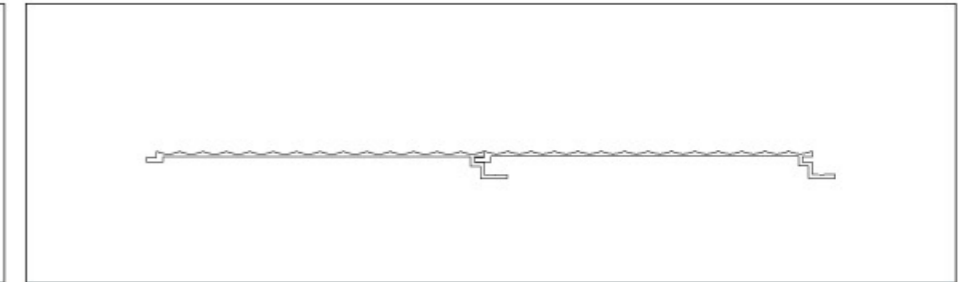

装配图

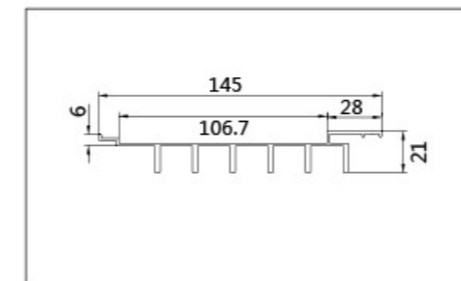

名称: CD-1123
壁厚: 1.3mm

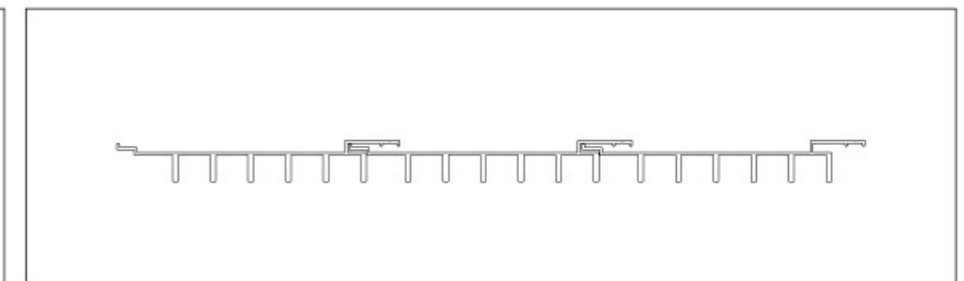

装配图

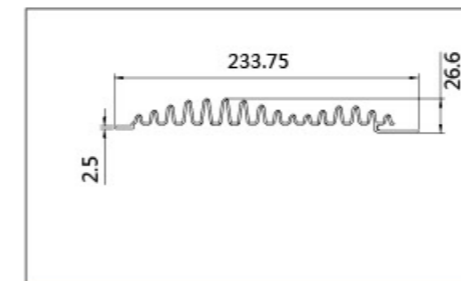

名称: CD-028
壁厚: 1.7mm

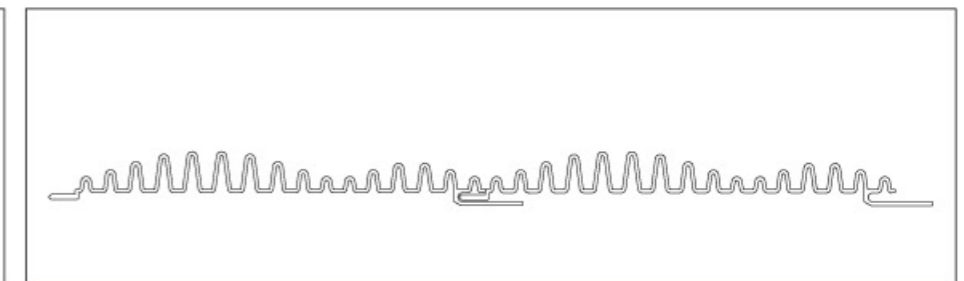

装配图

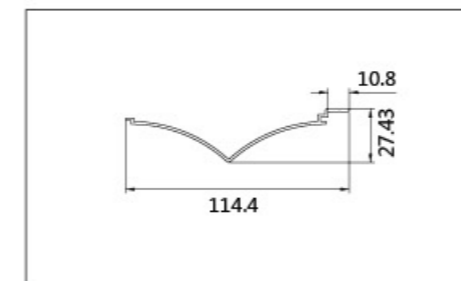

名称: CD-1293
壁厚: 1.5mm

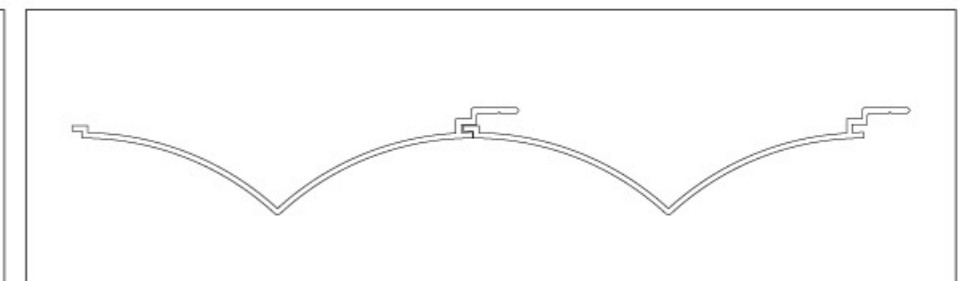

装配图

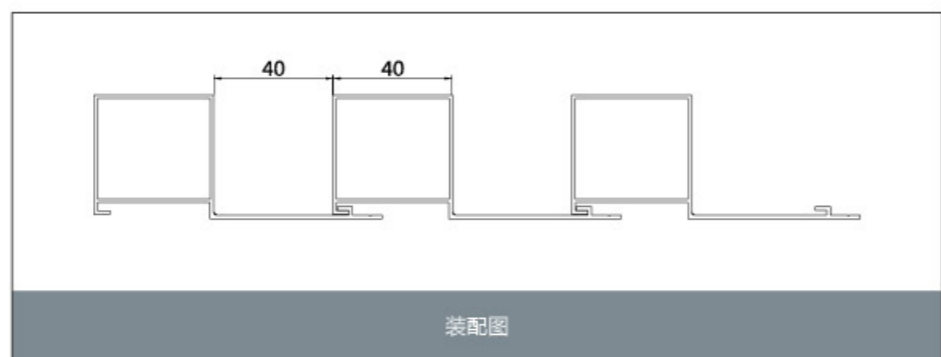
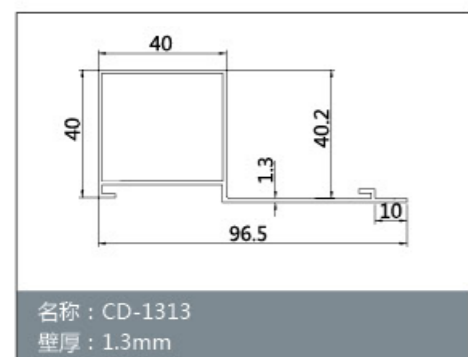
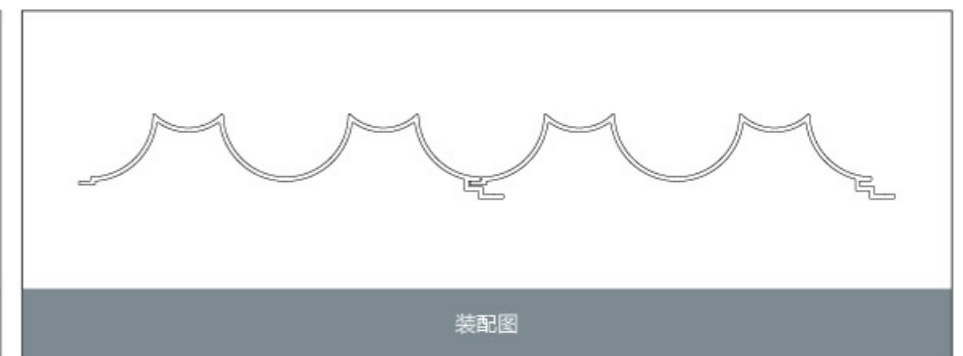
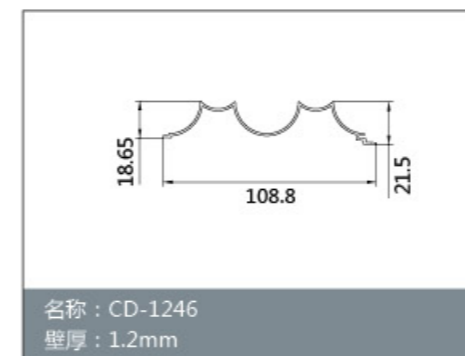
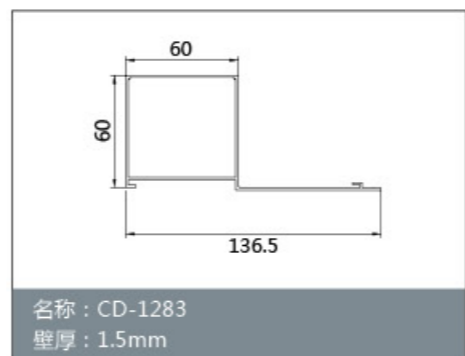
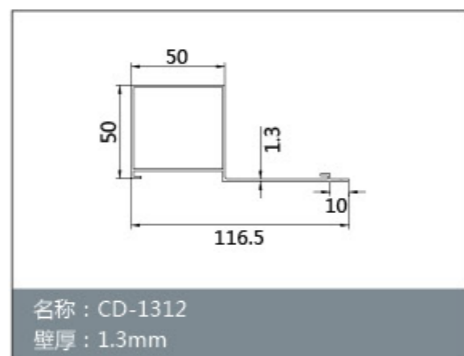
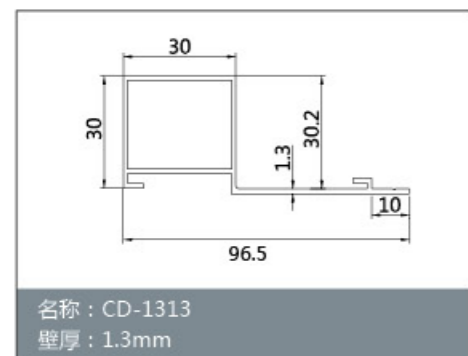
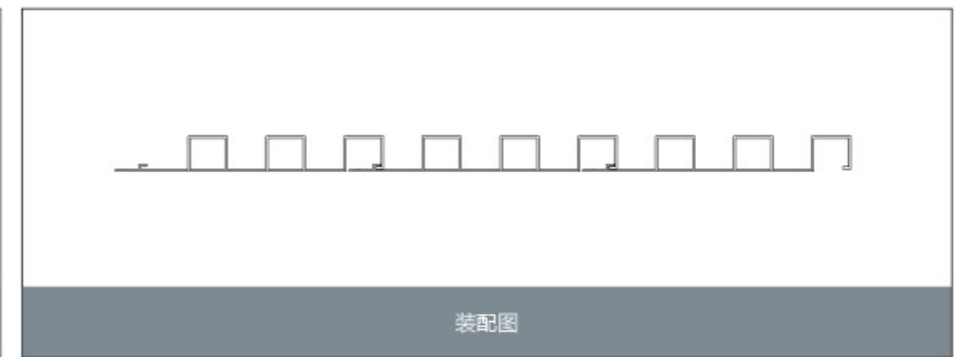
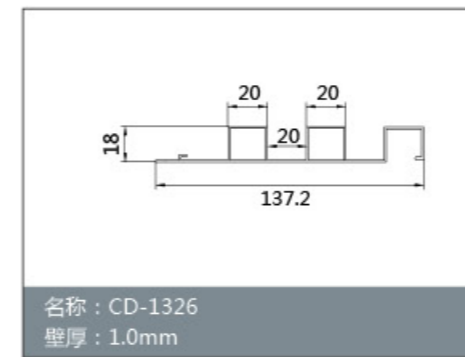
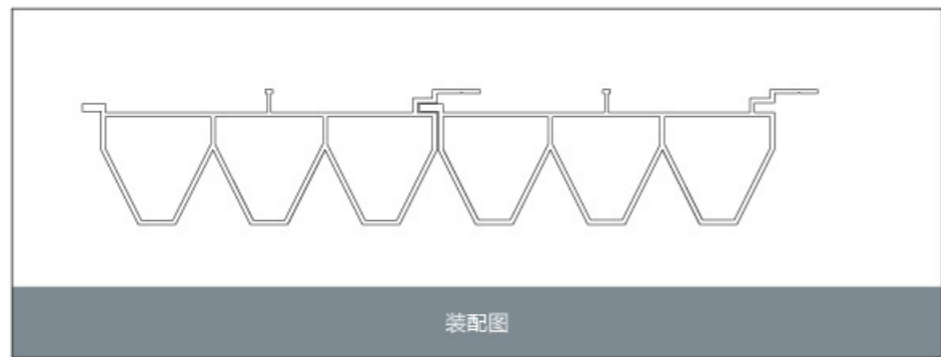
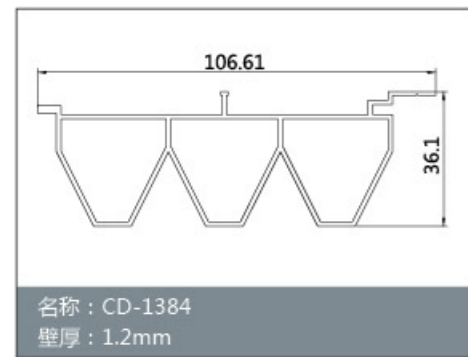
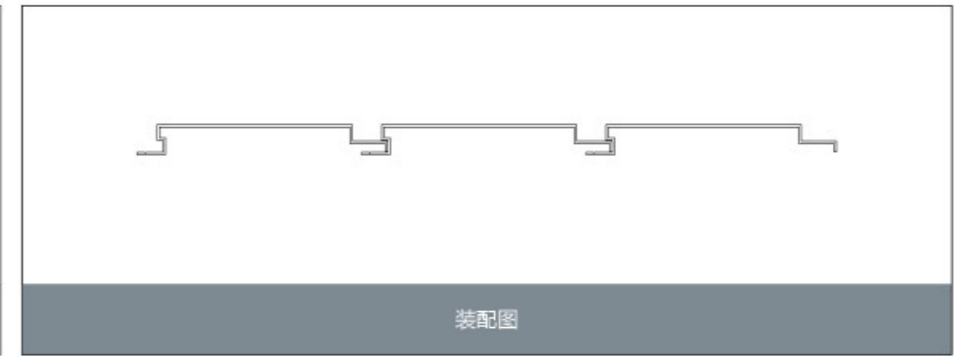
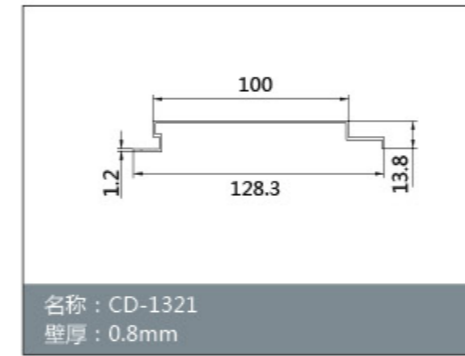
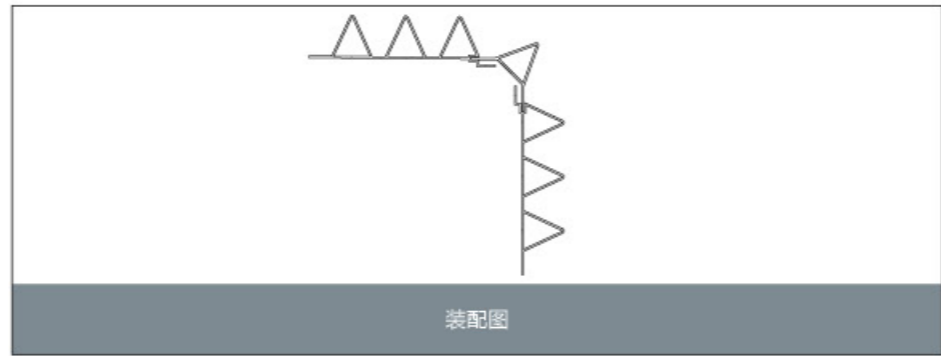
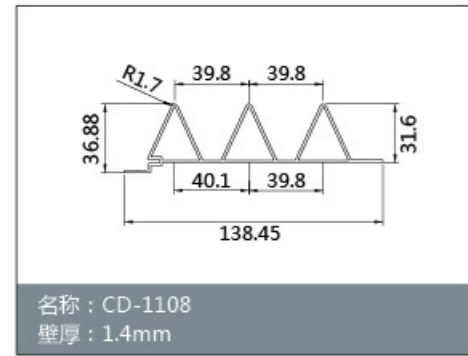
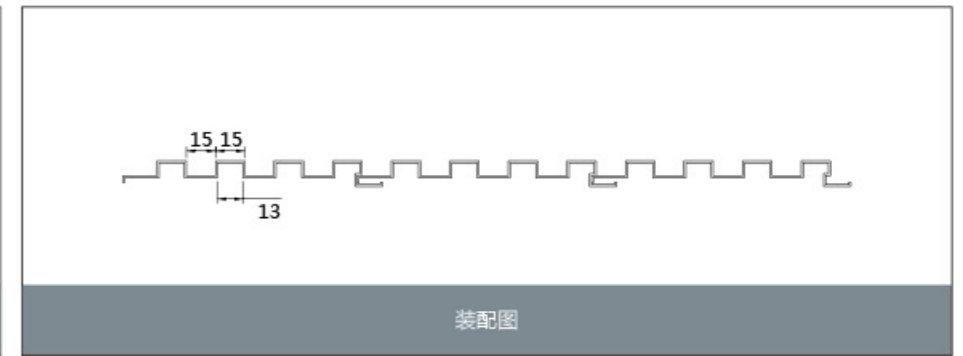
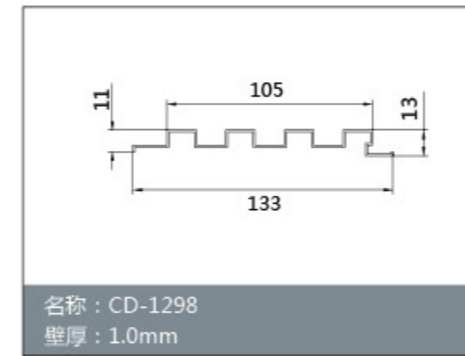
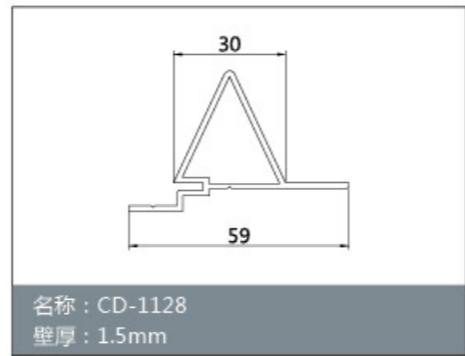
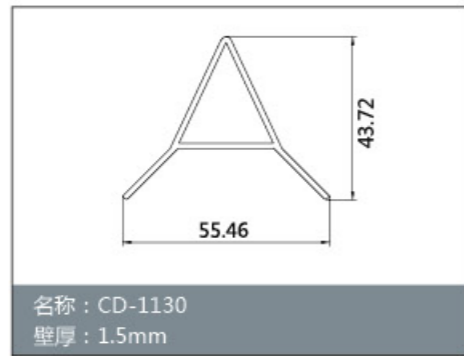
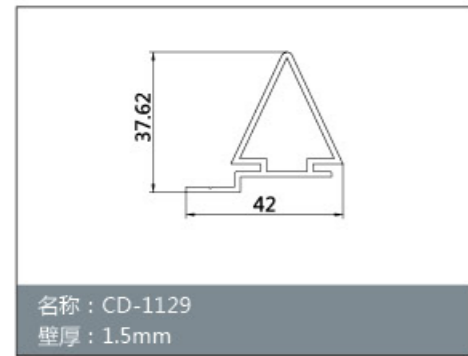

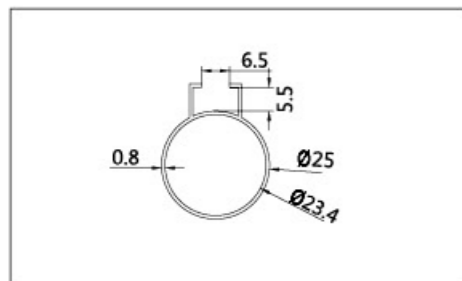
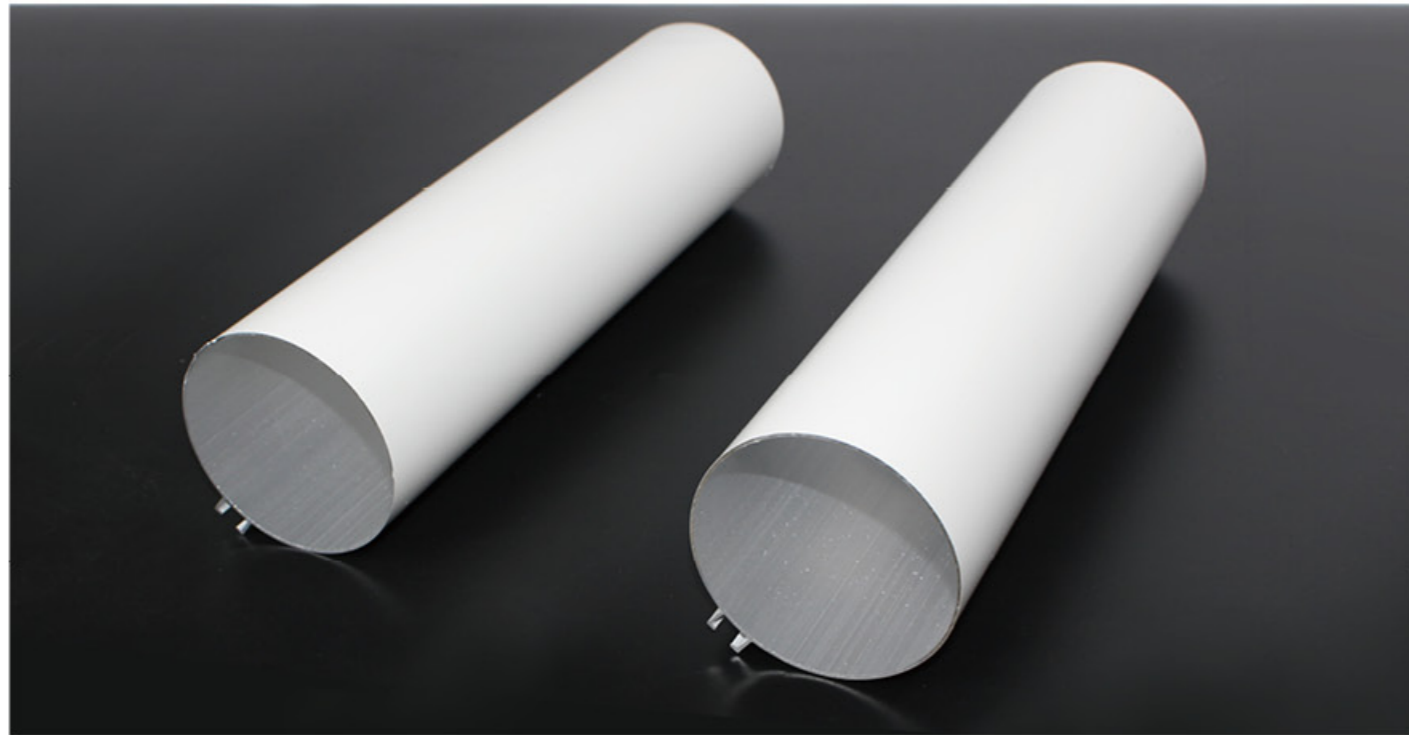

名称: 25YGTH
壁厚: 0.8mm

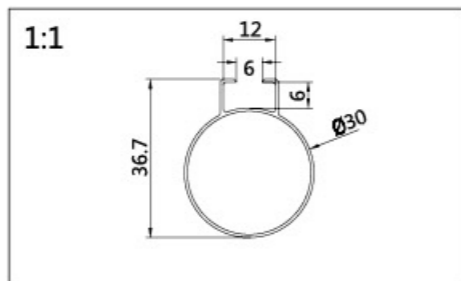

名称: CD-30
壁厚: 0.7mm

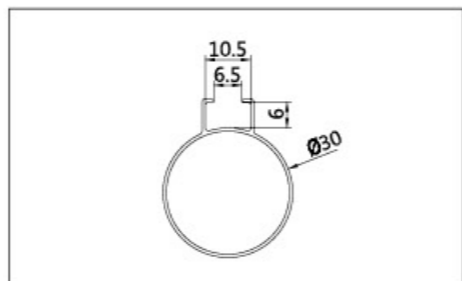

名称: CD-0866
壁厚: 0.75mm

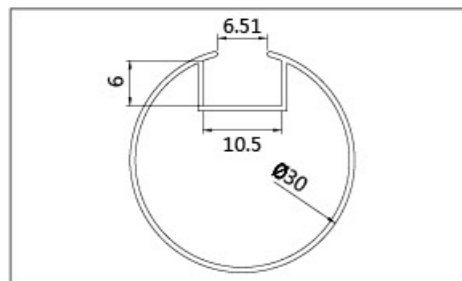

名称: 30x0.7ACTH
壁厚: 0.7mm

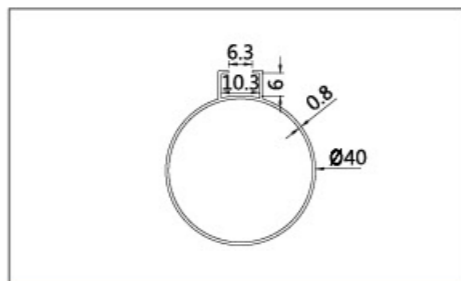

名称: 40x0.8TH
壁厚: 0.8mm

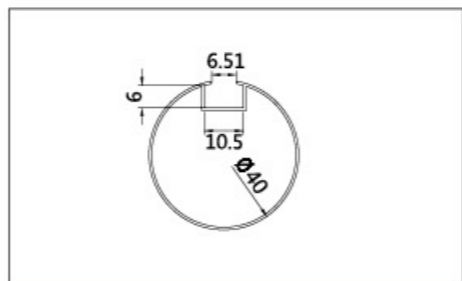

名称: 40x0.7ACTH
壁厚: 0.7mm

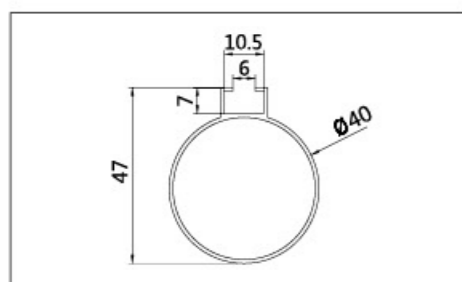

名称: CD-5040
壁厚: 1.0mm

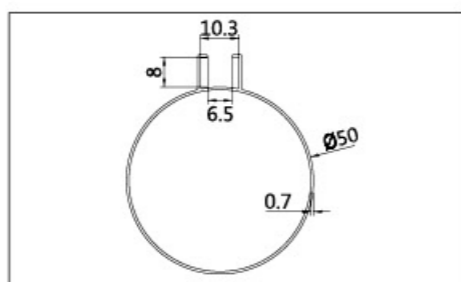

名称: CD-50TH
壁厚: 0.7mm

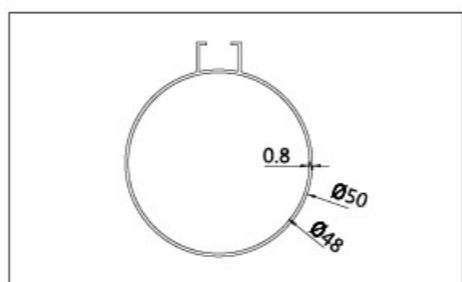

名称: 50YGTH
壁厚: 0.8mm

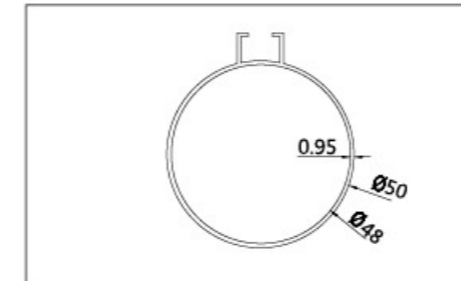

名称: CD-50YGTH
壁厚: 0.95mm

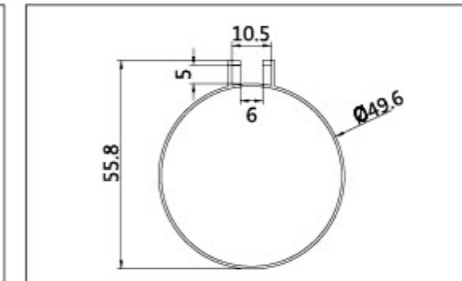

名称: CD-50YG-C
壁厚: 0.7mm

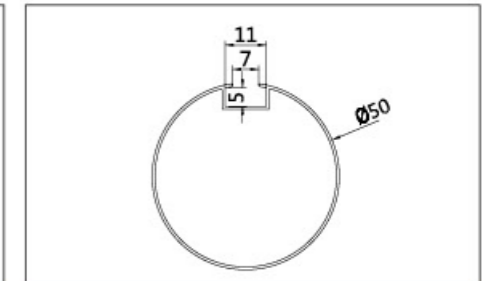

名称: CD-034
壁厚: 0.75 0.9 1.1mm

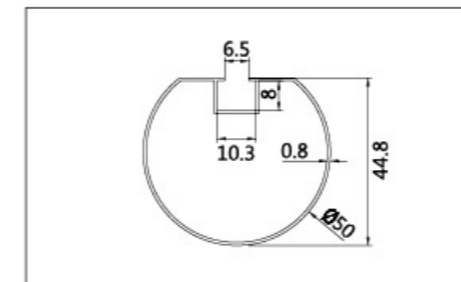

名称: CD-050TH
壁厚: 0.8mm

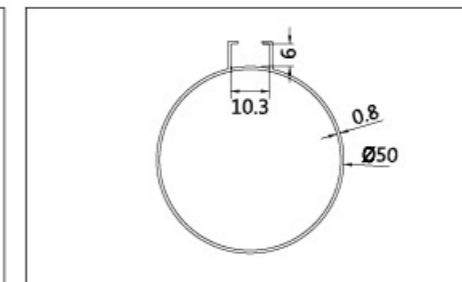

名称: 50x0.8TH
壁厚: 0.8 1.0 1.1mm

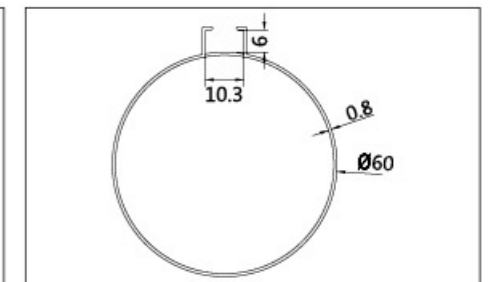

名称: 60x0.8TH
壁厚: 0.8 1.0mm

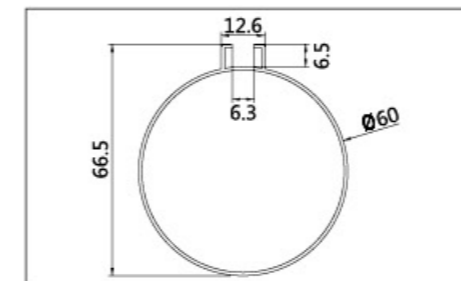

名称: CD-60
壁厚: 0.95mm

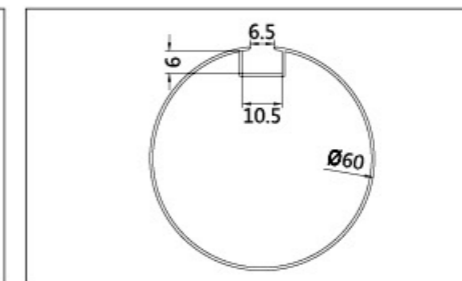

名称: 60x0.8ACTH
壁厚: 0.8 1.2mm

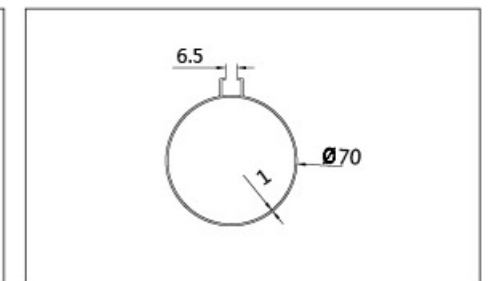

名称: CD-070TH
壁厚: 1.0 1.2mm

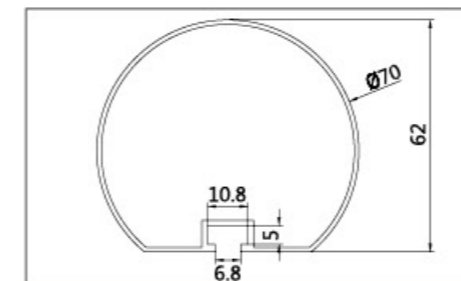

名称: CD-070
壁厚: 1.2mm

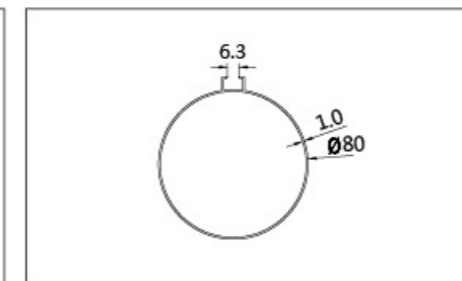

名称: 80x1.0TH
壁厚: 1.0 1.2mm

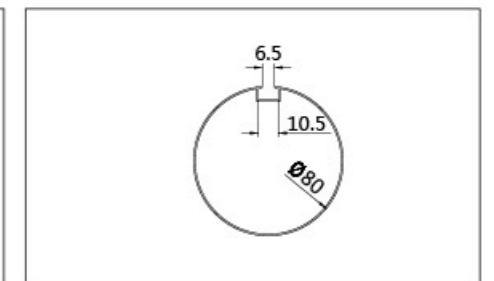

名称: 80x0.9ACTH
壁厚: 0.9 1.2mm

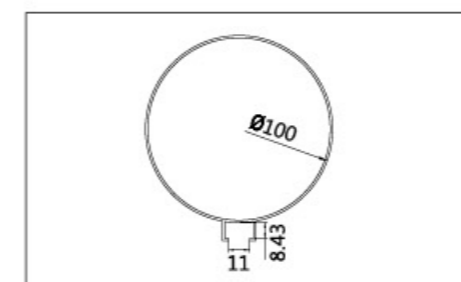

名称: CD-0795
壁厚: 1.35mm

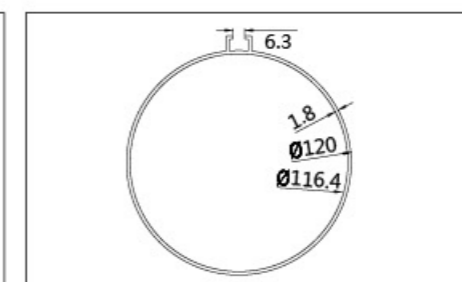

名称: 120x1.8TH
壁厚: 1.8mm

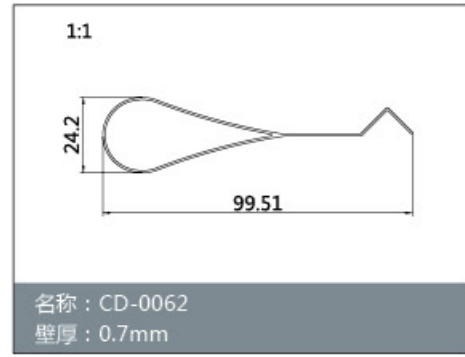

名称: CD-0062
壁厚: 0.7mm

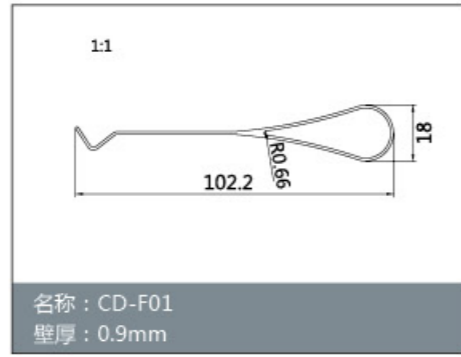

名称: CD-F01
壁厚: 0.9mm

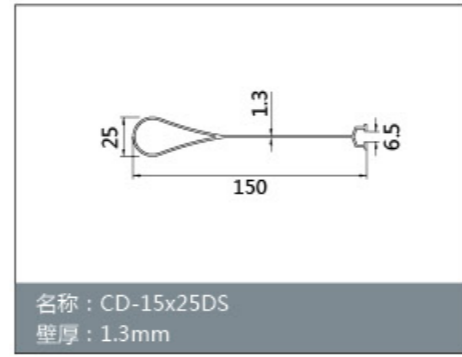

名称: CD-15x25DS
壁厚: 1.3mm

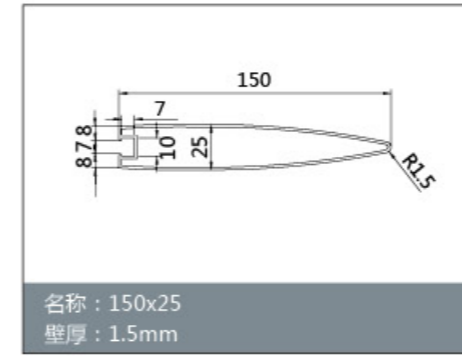

名称: 150x25
壁厚: 1.5mm

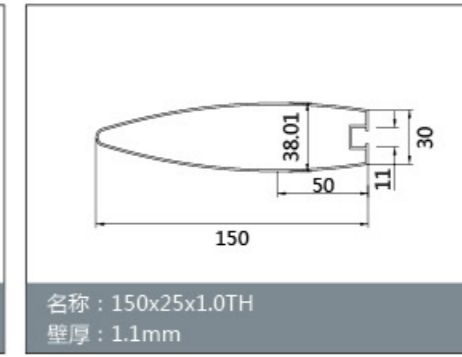

名称: 150x25x1.0TH
壁厚: 1.1mm

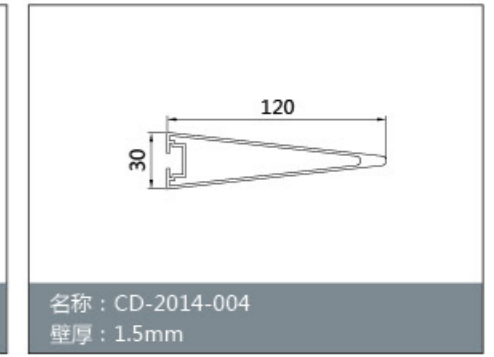

名称: CD-2014-004
壁厚: 1.5mm

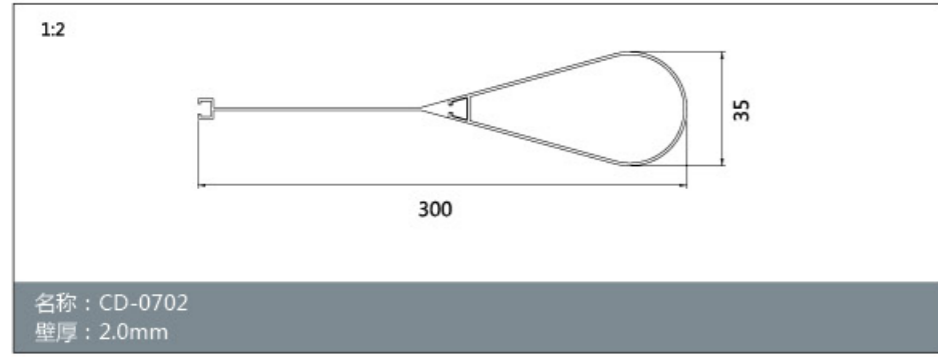

名称: CD-0702
壁厚: 2.0mm

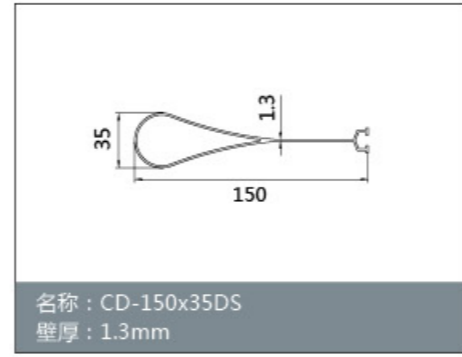

名称: CD-150x35DS
壁厚: 1.3mm

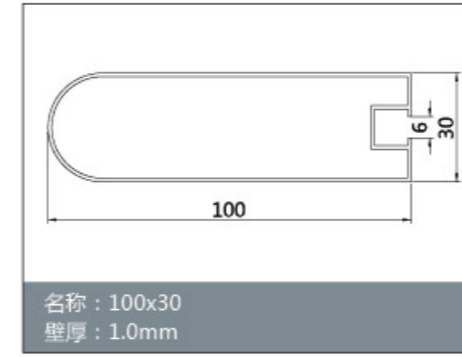

名称: 100x30
壁厚: 1.0mm

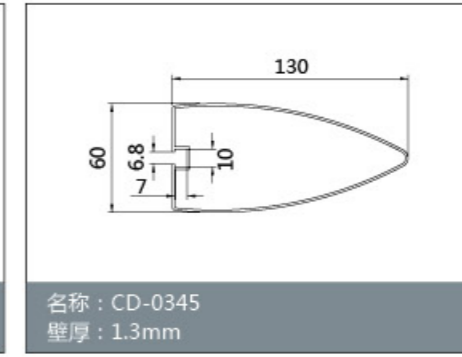

名称: CD-0345
壁厚: 1.3mm

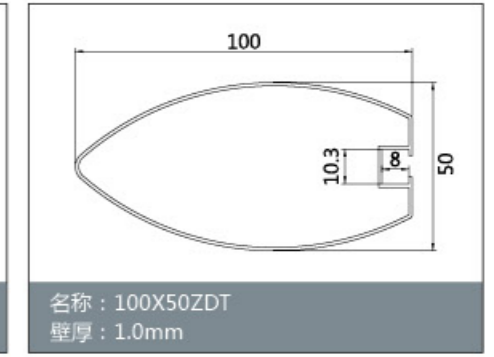

名称: 100X50ZDT
壁厚: 1.0mm

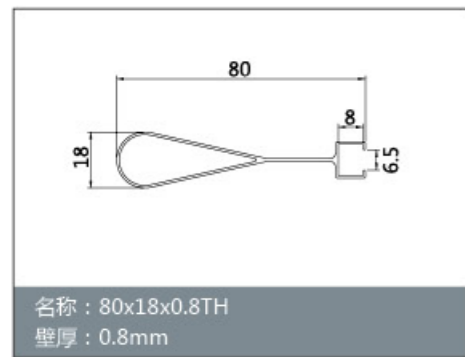

名称: 80x18x0.8TH
壁厚: 0.8mm

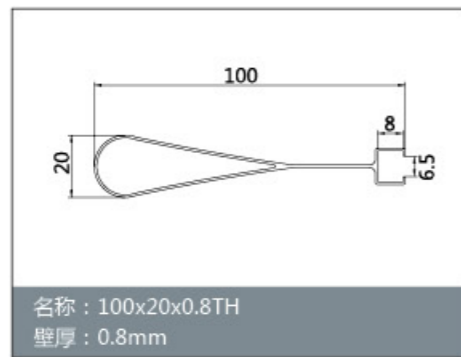

名称: 100x20x0.8TH
壁厚: 0.8mm

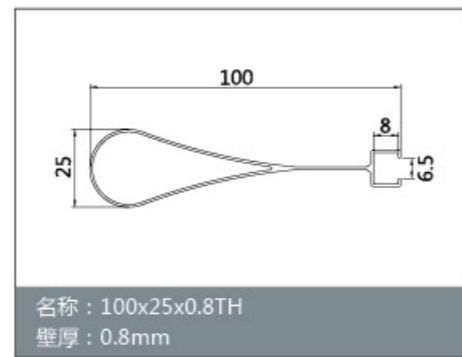

名称: 100x25x0.8TH
壁厚: 0.8mm

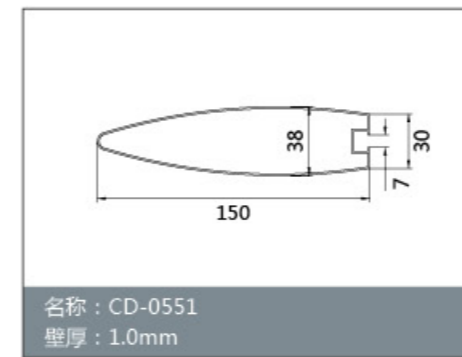

名称: CD-0551
壁厚: 1.0mm

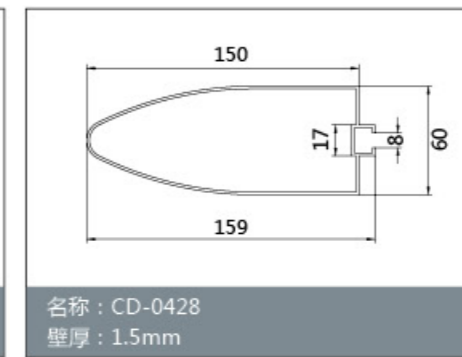

名称: CD-0428
壁厚: 1.5mm

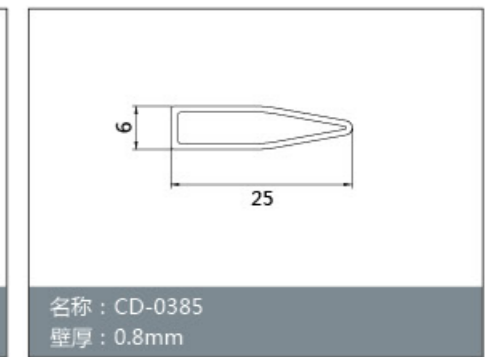

名称: CD-0385
壁厚: 0.8mm

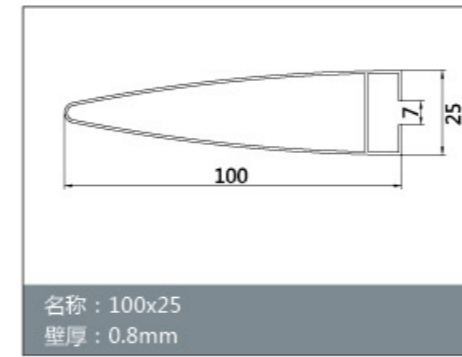

名称: 100x25
壁厚: 0.8mm

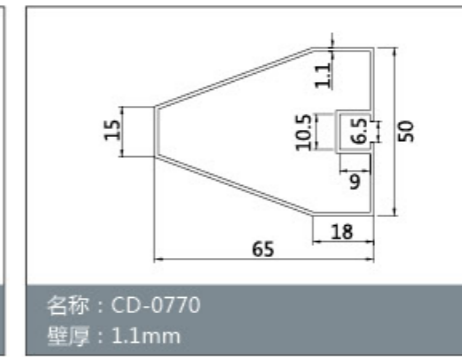

名称: CD-0770
壁厚: 1.1mm

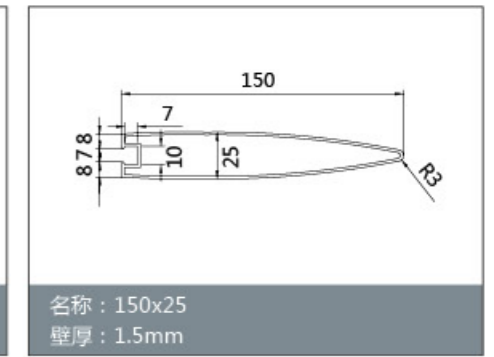

名称: 150x25
壁厚: 1.5mm

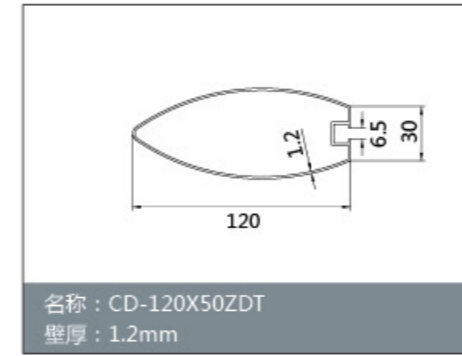

名称: CD-120X50ZDT
壁厚: 1.2mm

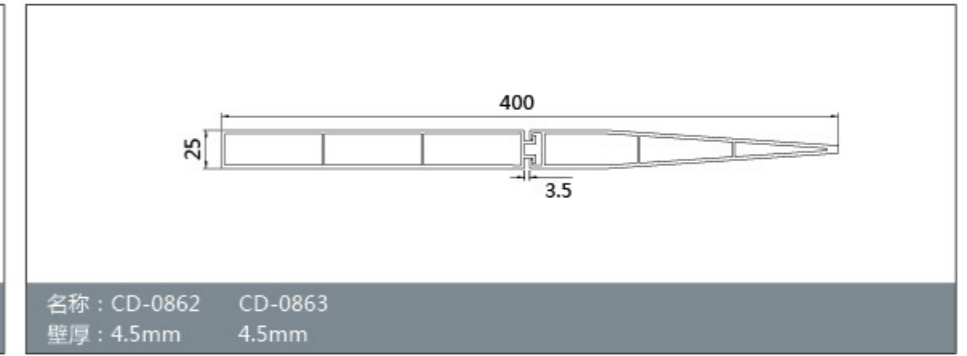

名称: CD-0862 CD-0863
壁厚: 4.5mm 4.5mm

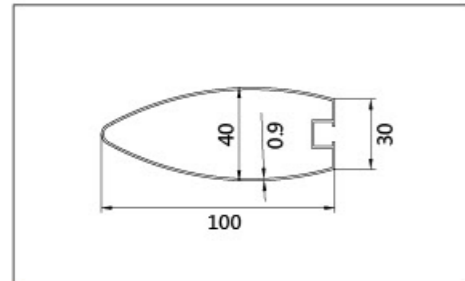

名称：100x40x0.9TH
壁厚：0.9mm

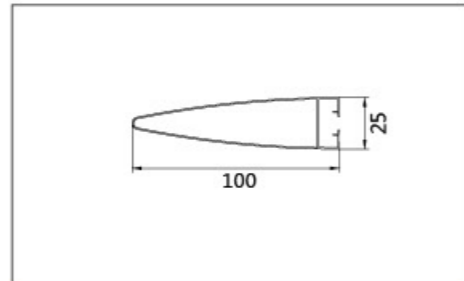

名称：100x20x0.7TH
壁厚：0.7mm

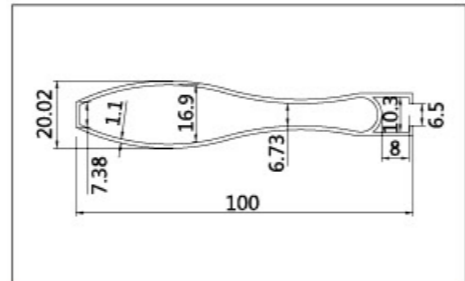

名称：CD-1026
壁厚：1.1mm

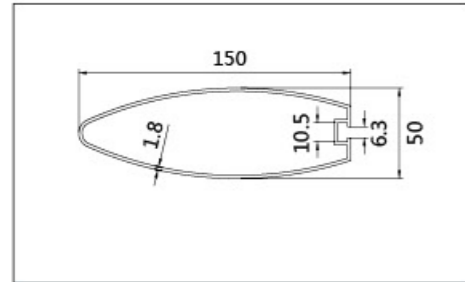

名称：CD-2014-028
壁厚：1.8mm

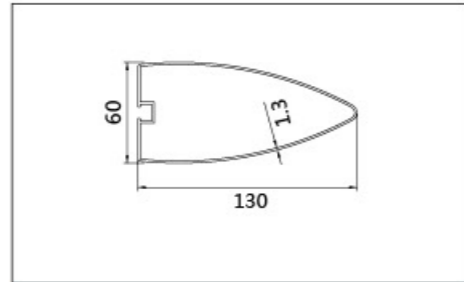

名称：CD-0345
壁厚：1.3mm

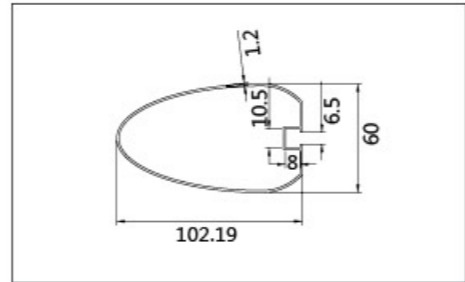

名称：CD-1270
壁厚：1.2mm

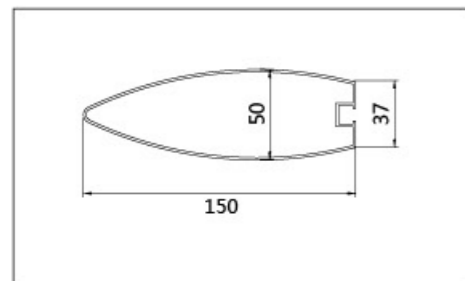

名称：150x50ZDT
壁厚：1.4mm

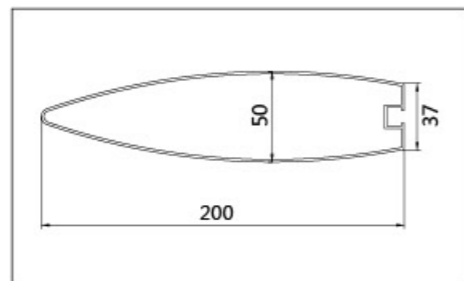

名称：200x50ZDT
壁厚：2.0mm

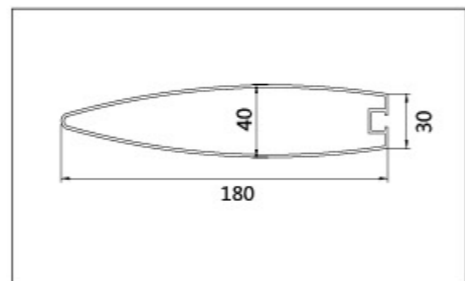

名称：180x40ZDT
壁厚：1.6mm

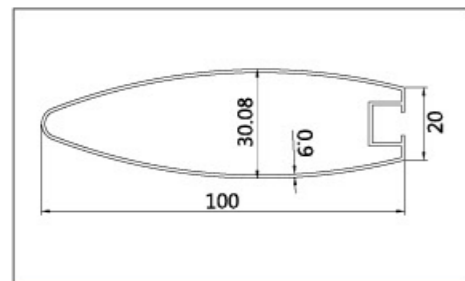

名称：100x30x0.9ZDT
壁厚：0.9mm

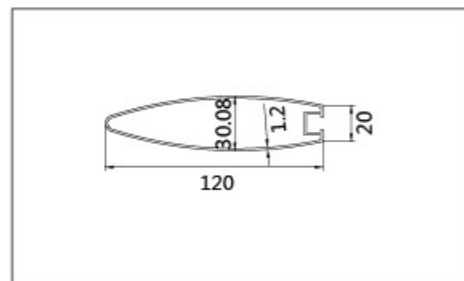

名称：CD-120x30ZDT
壁厚：1.2mm

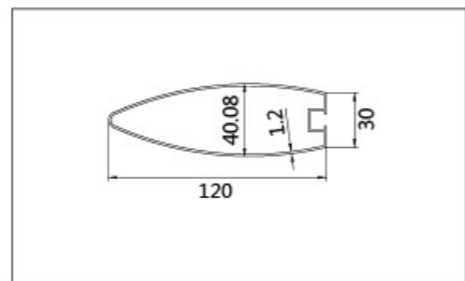

名称：120x40x1.2ZDT
壁厚：1.2mm

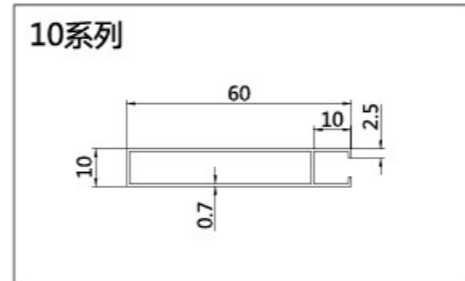

名称：CD-0760
壁厚：0.7mm

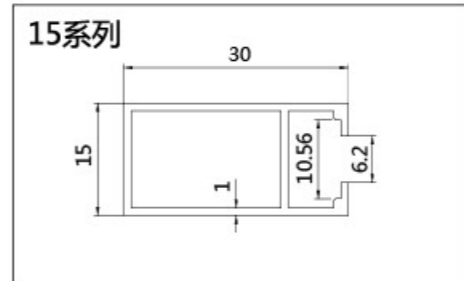

名称：CD-0814
壁厚：1.0mm

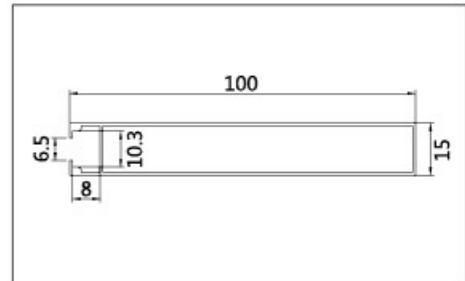

名称：CD-0992
壁厚：0.8 1.0mm

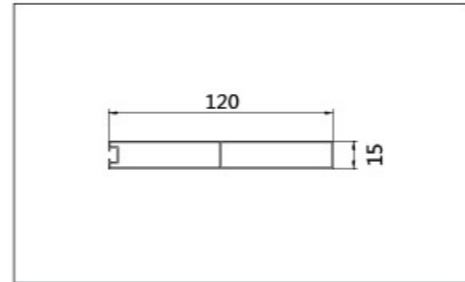

名称：CD-001
壁厚：1.6mm

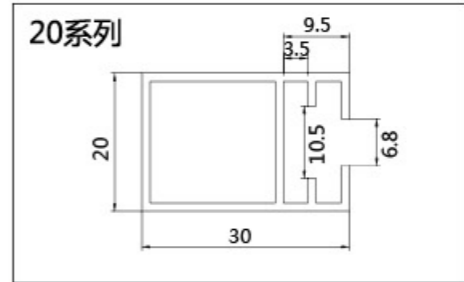

名称：CD-0926
壁厚：1.2mm

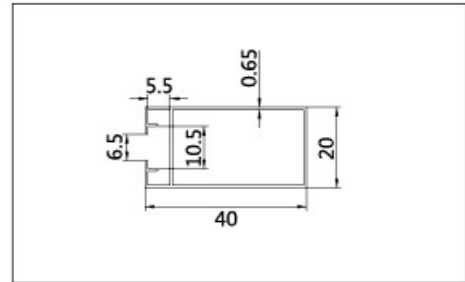

名称：40x20TH
壁厚：0.65 0.8mm

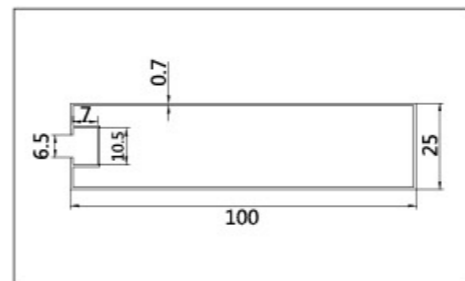

名称：100x25x0.7TH
壁厚：0.7mm

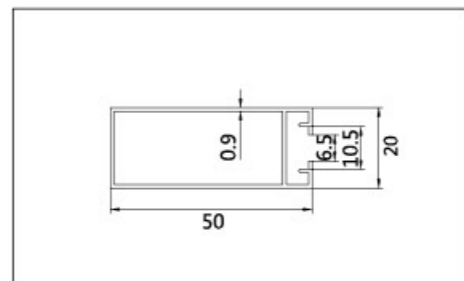

名称：50x20TH
壁厚：0.7 0.9 1.0mm

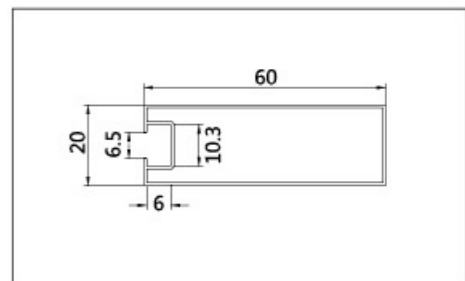

名称：60x20TH
壁厚：0.8 1.0mm

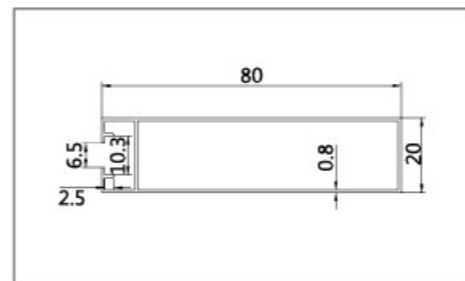

名称：80x20x0.8TH
壁厚：0.62 0.8 1.0mm

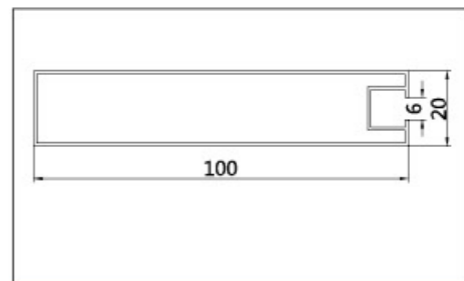

名称：100x20
壁厚：0.8 1.0 1.2mm

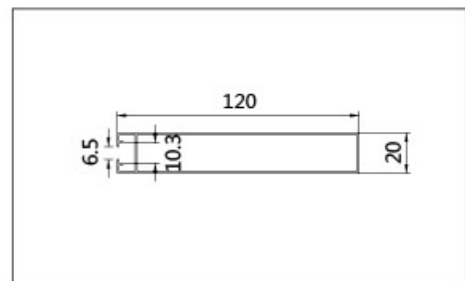

名称：120x20x0.95TH
壁厚：0.95 1.2mm

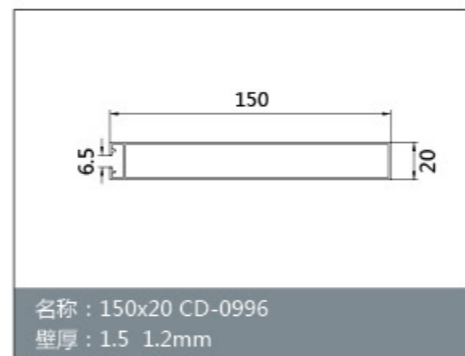

名称：150x20 CD-0996
壁厚：1.5 1.2mm

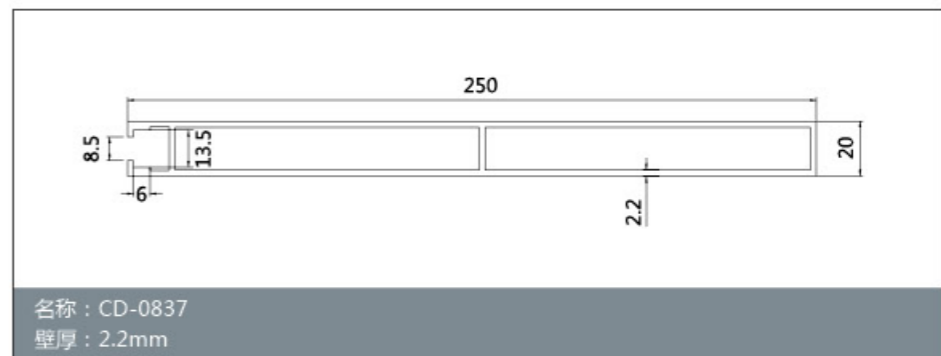

名称：CD-0837
壁厚：2.2mm

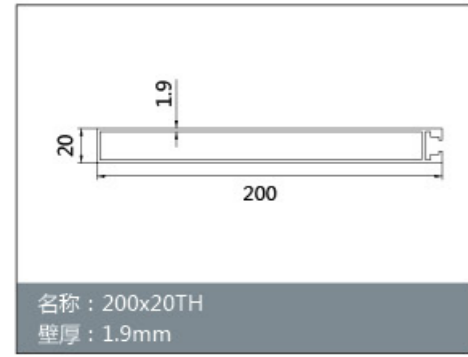

名称: 200x20TH
壁厚: 1.9mm

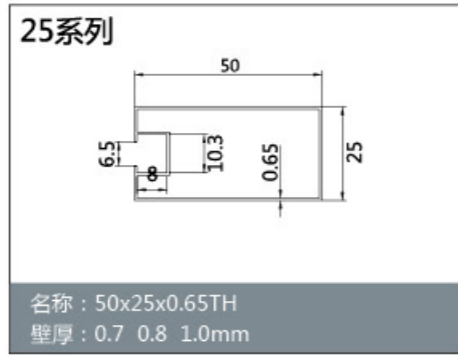

名称: 50x25x0.65TH
壁厚: 0.7 0.8 1.0mm

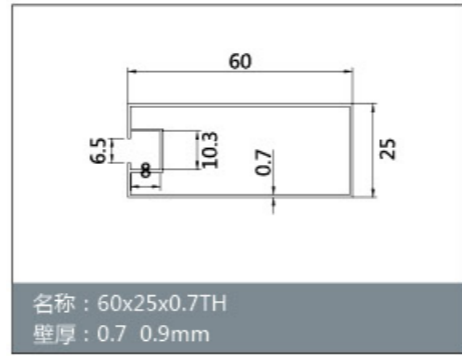

名称: 60x25x0.7TH
壁厚: 0.7 0.9mm

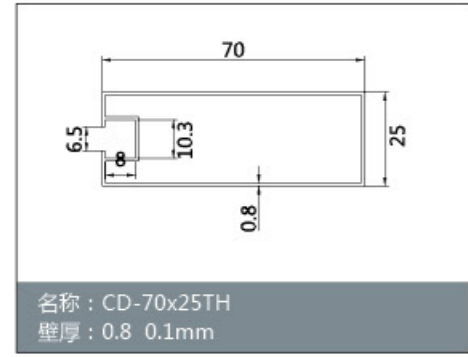

名称: CD-70x25TH
壁厚: 0.8 0.1mm

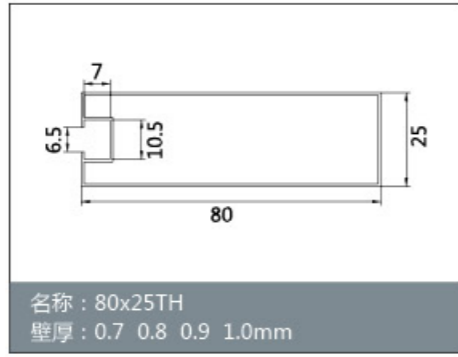

名称: 80x25TH
壁厚: 0.7 0.8 0.9 1.0mm

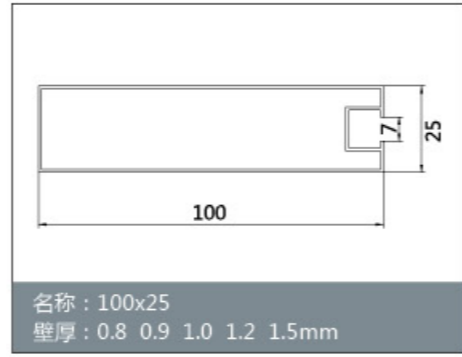

名称: 100x25
壁厚: 0.8 0.9 1.0 1.2 1.5mm

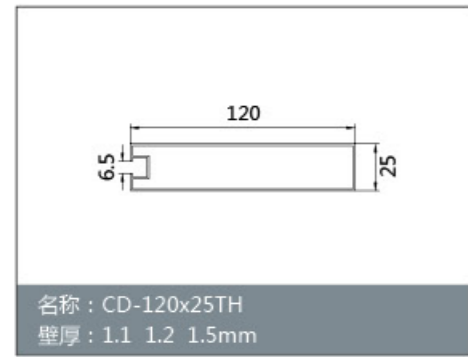

名称: CD-120x25TH
壁厚: 1.1 1.2 1.5mm

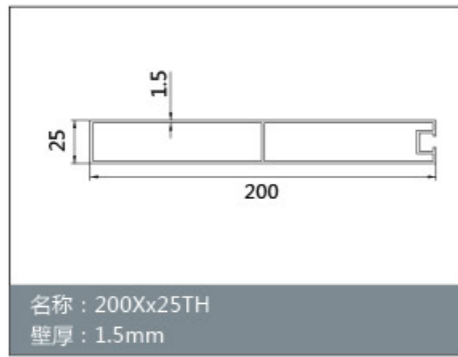

名称: 200x25TH
壁厚: 1.5mm

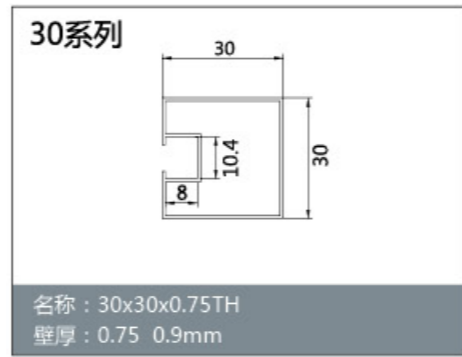

名称: 30x30x0.75TH
壁厚: 0.75 0.9mm

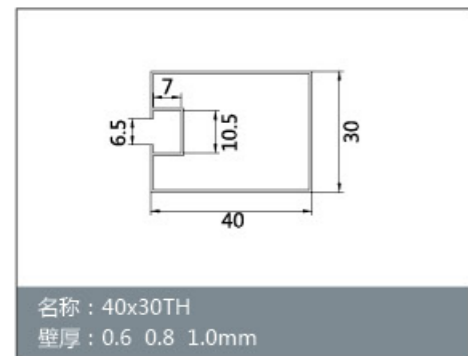

名称: 40x30TH
壁厚: 0.6 0.8 1.0mm

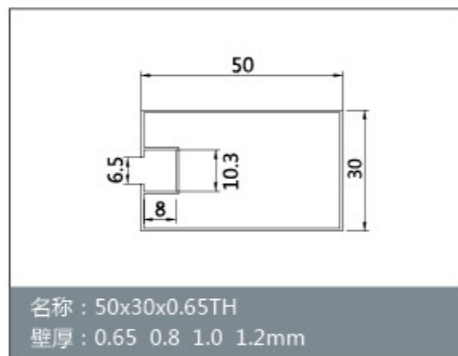

名称: 50x30x0.65TH
壁厚: 0.65 0.8 1.0 1.2mm

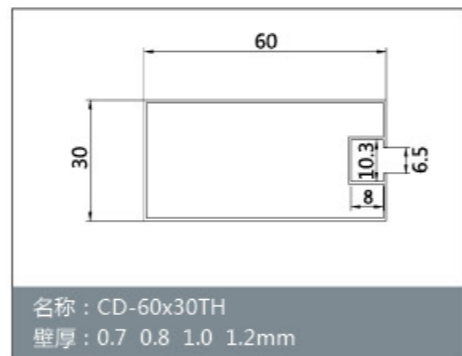

名称: CD-60x30TH
壁厚: 0.7 0.8 1.0 1.2mm

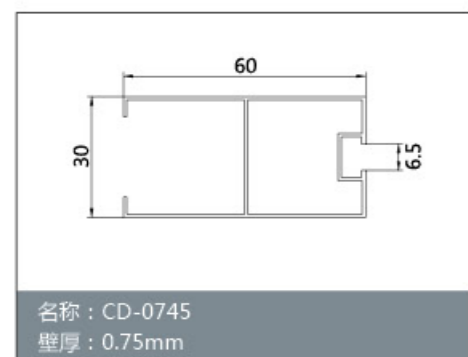

名称: CD-0745
壁厚: 0.75mm

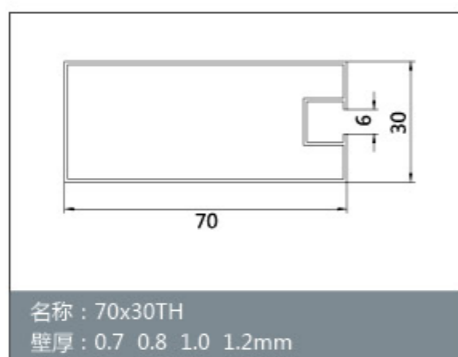

名称: 70x30TH
壁厚: 0.7 0.8 1.0 1.2mm

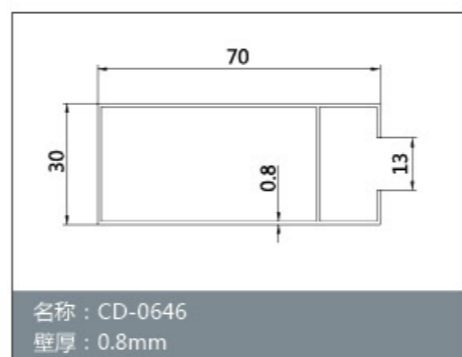

名称: CD-0646
壁厚: 0.8mm

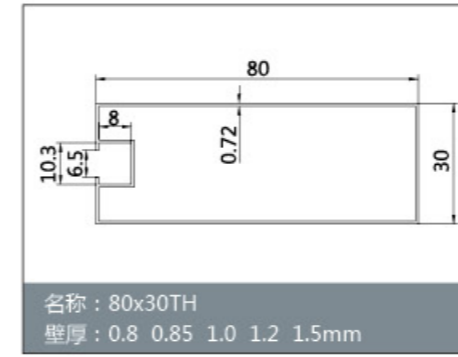

名称: 80x30TH
壁厚: 0.8 0.85 1.0 1.2 1.5mm

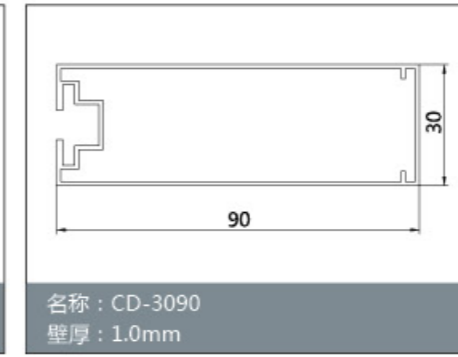

名称: CD-3090
壁厚: 1.0mm

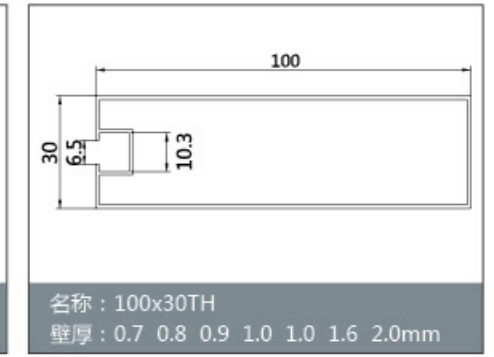

名称: 100x30TH
壁厚: 0.7 0.8 0.9 1.0 1.0 1.6 2.0mm

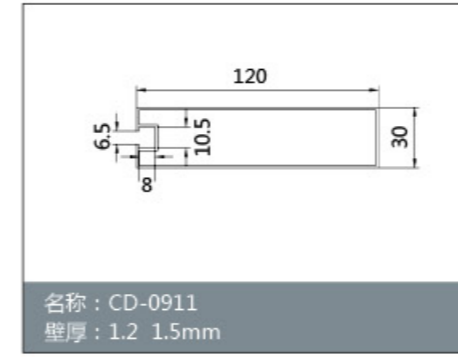

名称: CD-0911
壁厚: 1.2 1.5mm

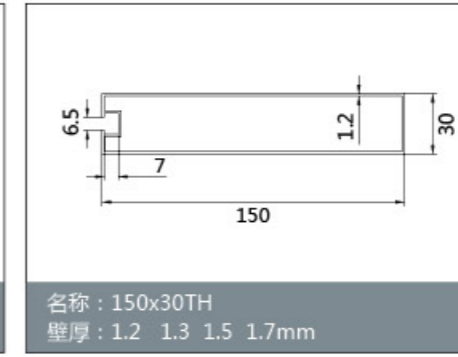

名称: 150x30TH
壁厚: 1.2 1.3 1.5 1.7mm

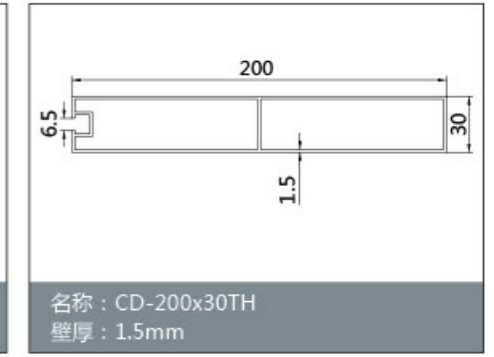

名称: CD-200x30TH
壁厚: 1.5mm

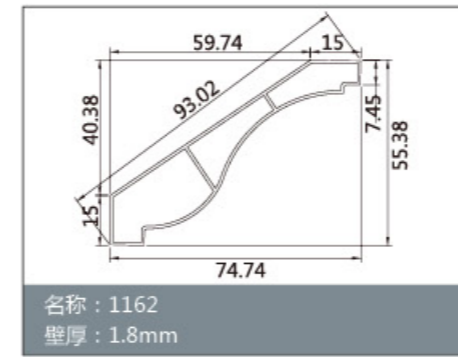

名称: 1162
壁厚: 1.8mm

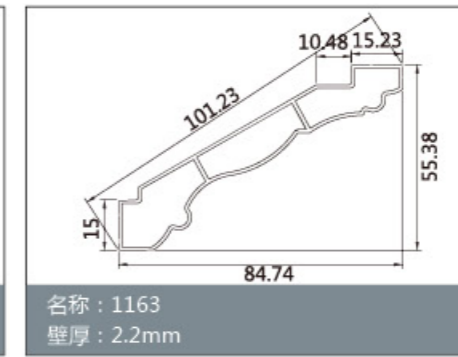

名称: 1163
壁厚: 2.2mm

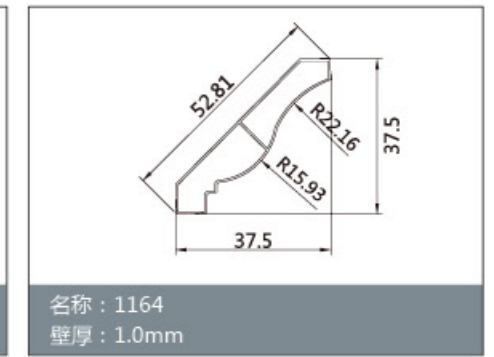

名称: 1164
壁厚: 1.0mm



名称: 1165
壁厚: 1.5mm

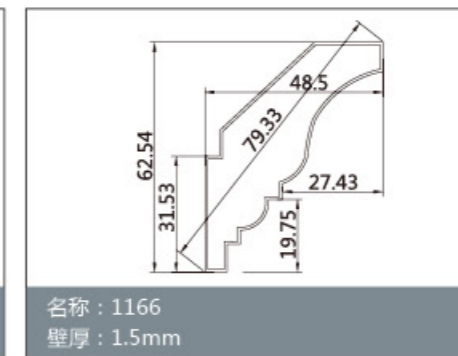

名称: 1166
壁厚: 1.5mm

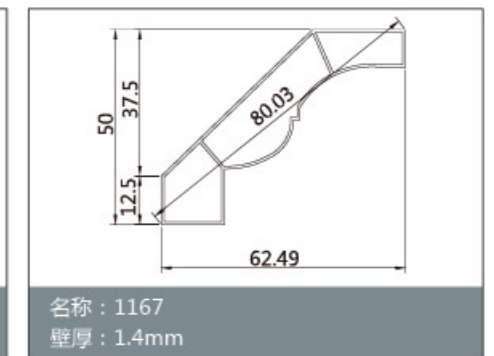

名称: 1167
壁厚: 1.4mm

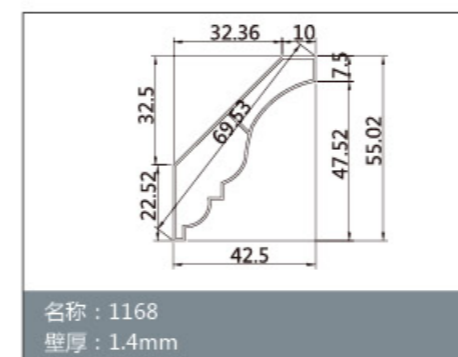

名称: 1168
壁厚: 1.4mm

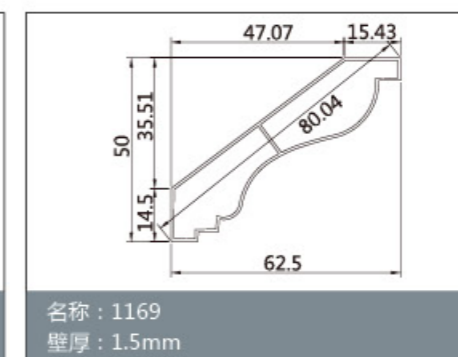

名称: 1169
壁厚: 1.5mm



名称: CD-200x30TH
壁厚: 1.5mm

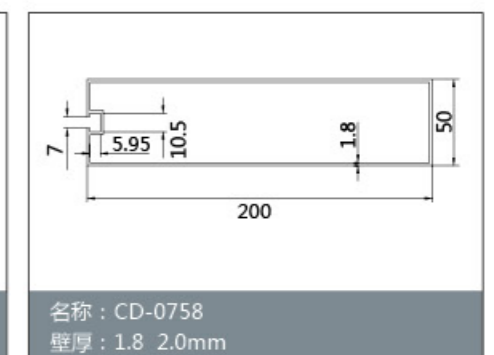
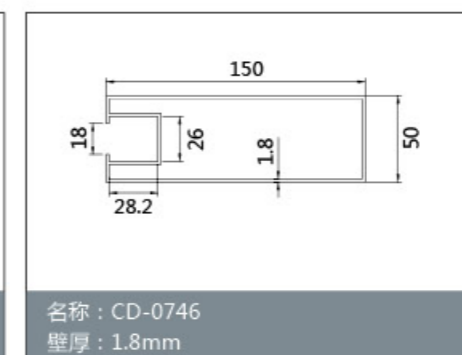
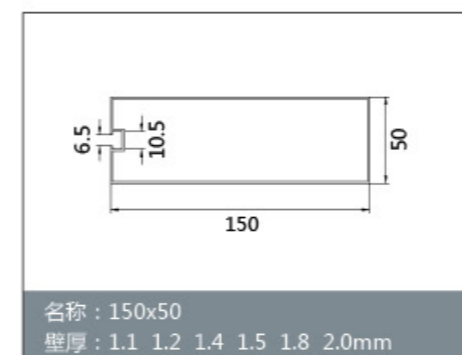
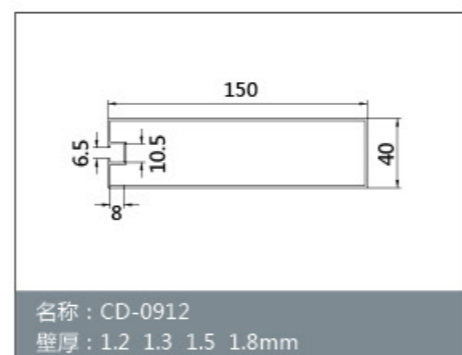
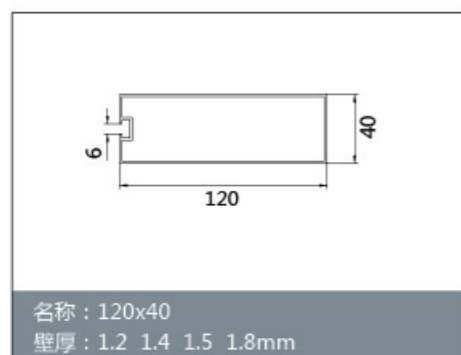
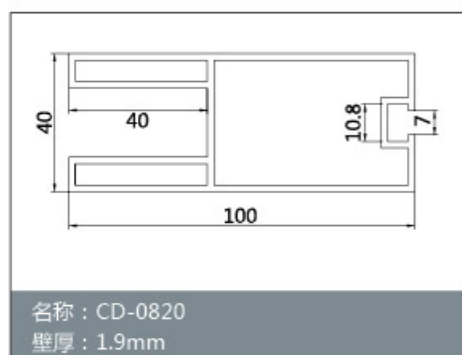
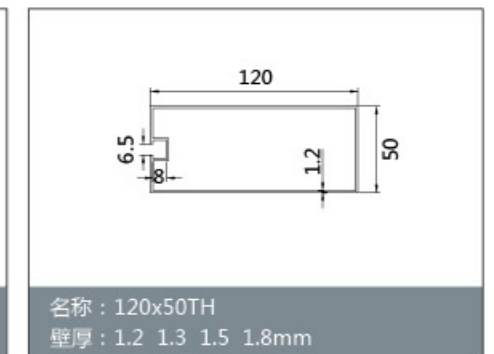
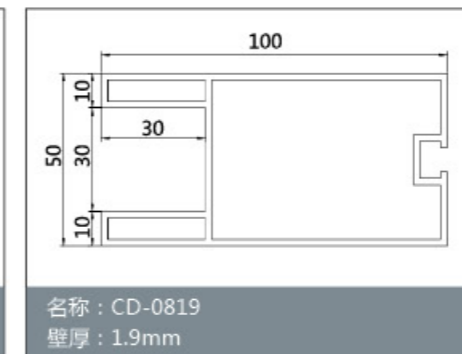
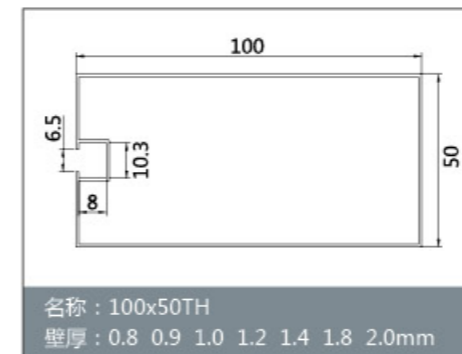
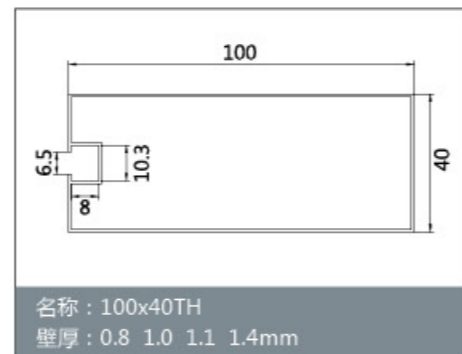
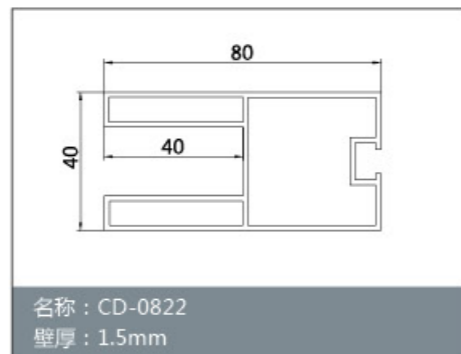
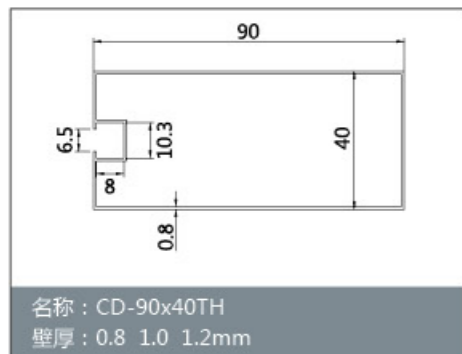
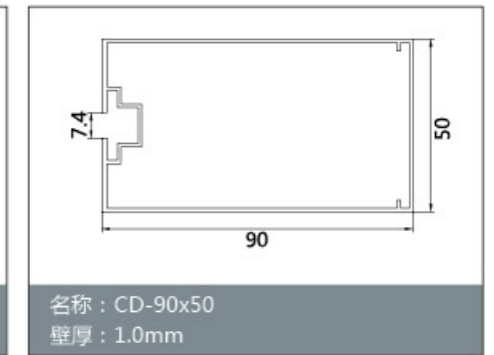
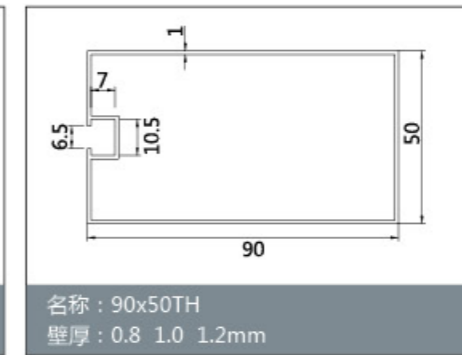
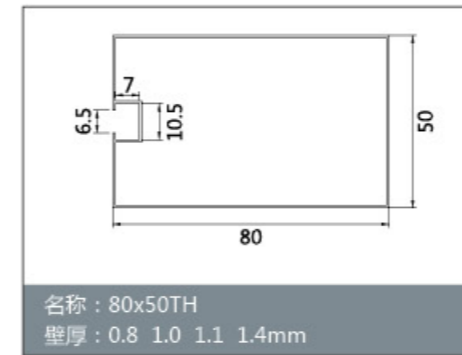
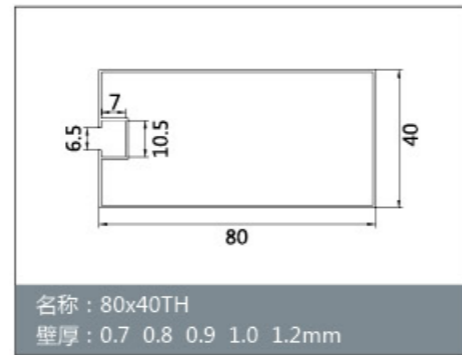
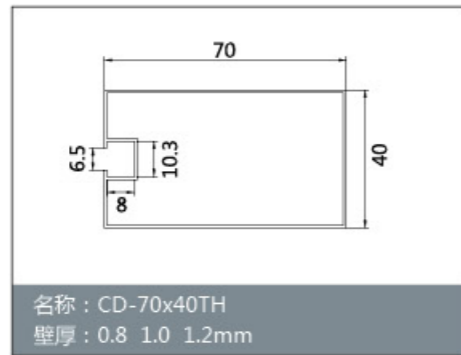
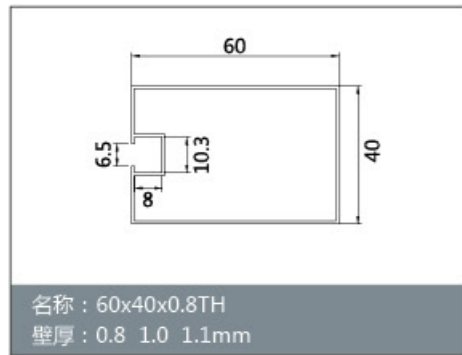
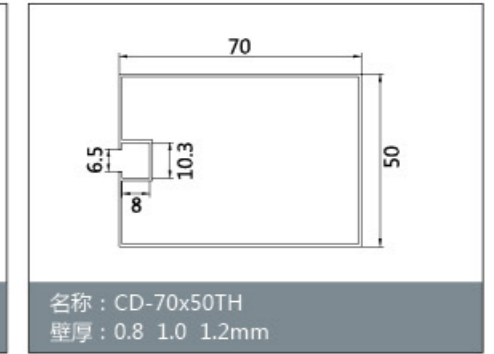
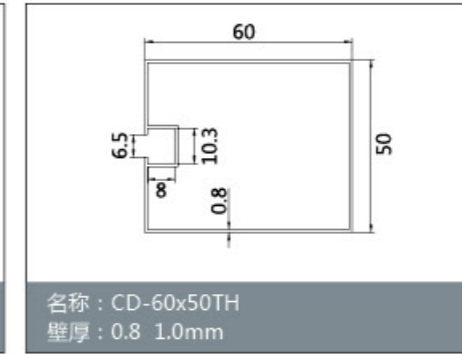
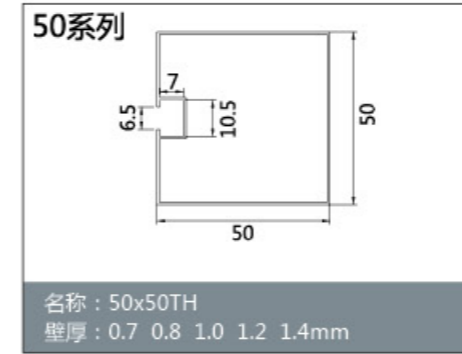
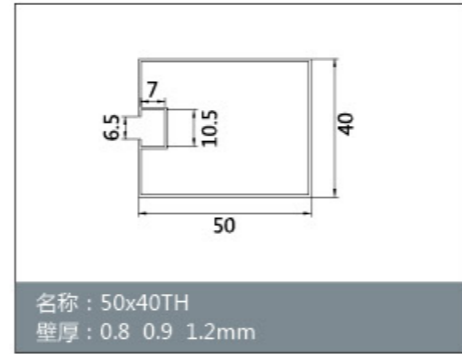
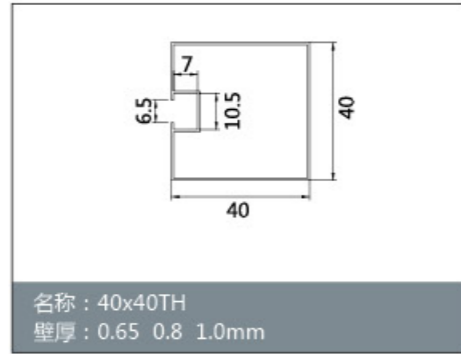
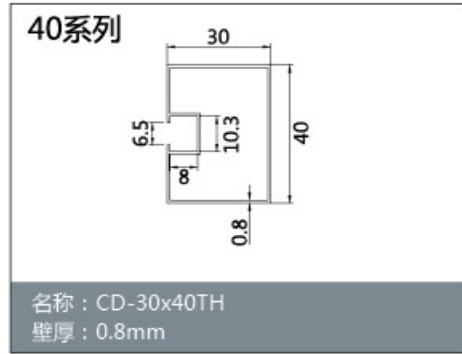
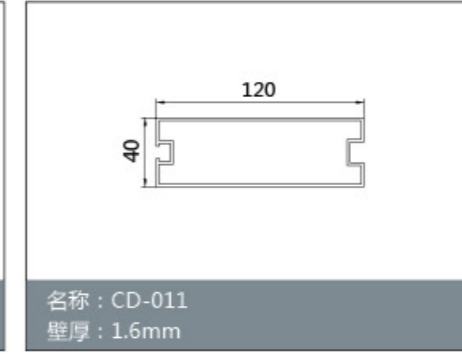
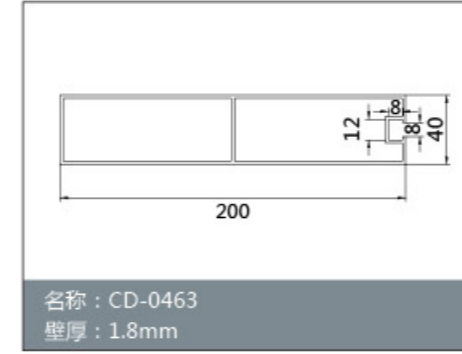
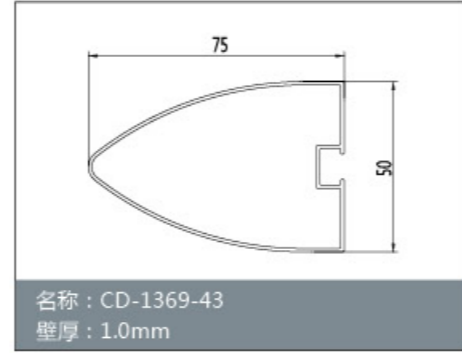
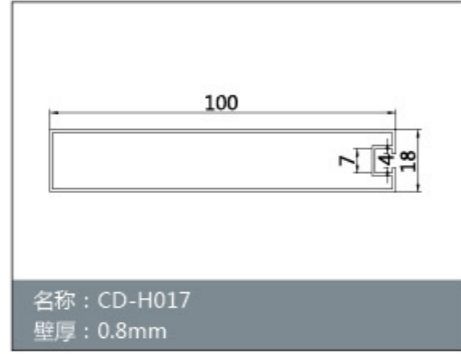
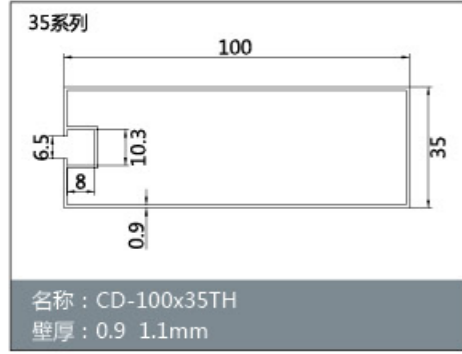

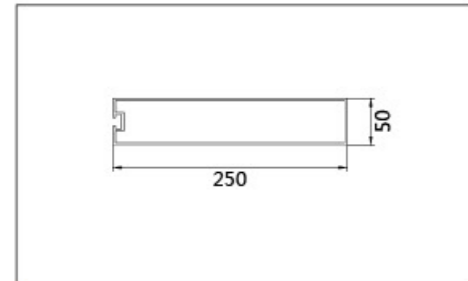

名称: CD-2014-031
壁厚: 2.5mm

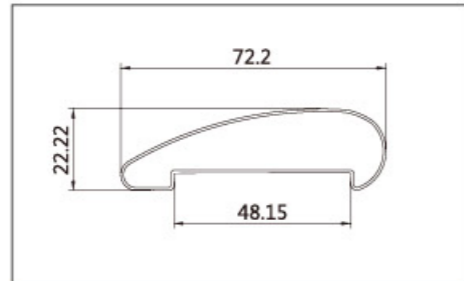

名称: CD-0932
壁厚: 1.4mm

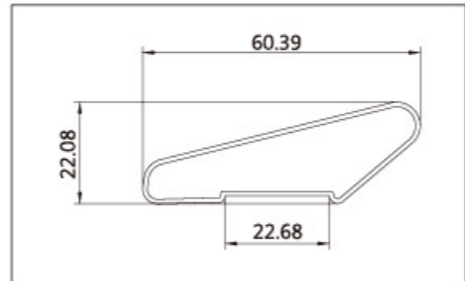

名称: CD-0933
壁厚: 2.0mm

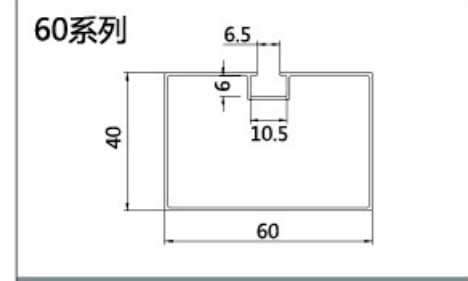

名称: CD-0865
壁厚: 0.9mm

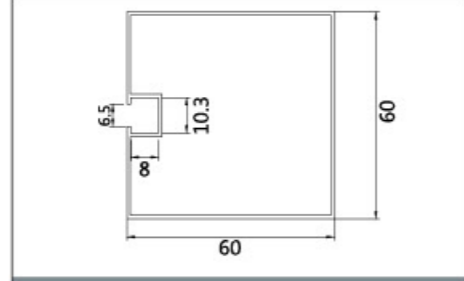

名称: CD-60x60TH
壁厚: 1.0 1.2mm

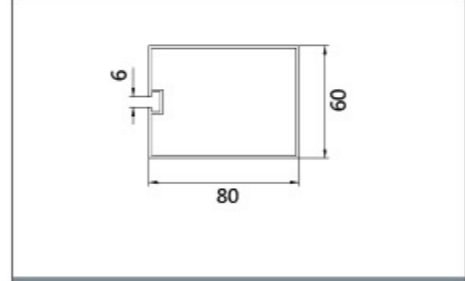

名称: 80x60
壁厚: 1.0 1.2 1.3mm

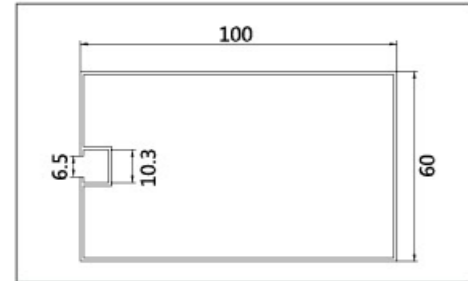

名称: 100x60x1.0TH
壁厚: 1.0 1.2mm

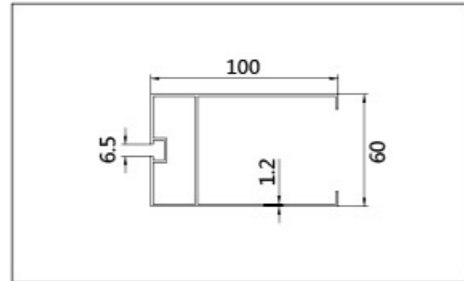

名称: CD-0649
壁厚: 1.2mm

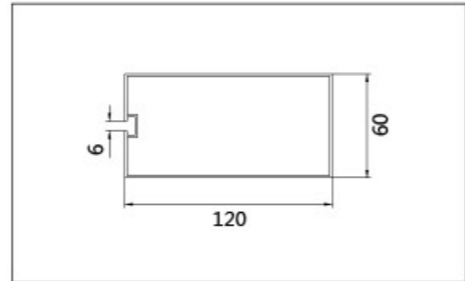

名称: 120x60
壁厚: 1.7mm

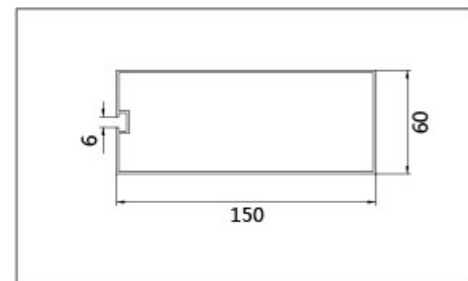

名称: 150x60
壁厚: 1.5 1.8mm

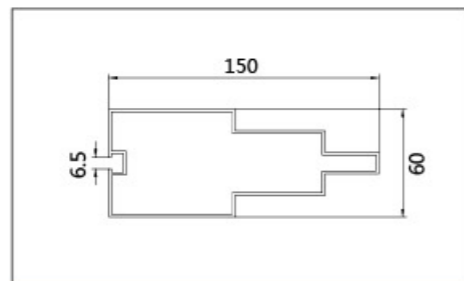

名称: CD-1058
壁厚: 1.5mm

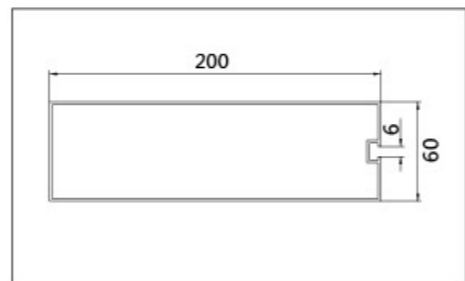

名称: CD-0541
壁厚: 1.7mm

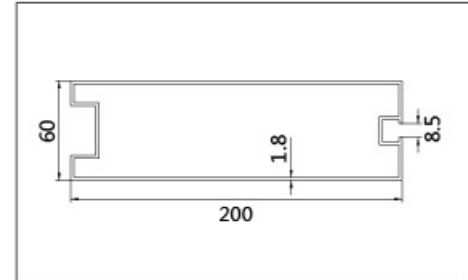

名称: CD-0997
壁厚: 1.8mm

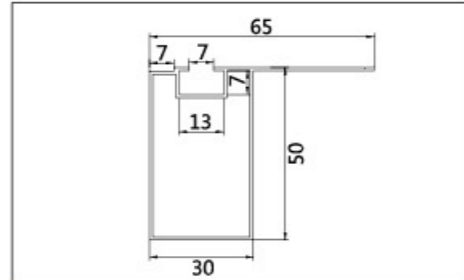

名称: CD-0929
壁厚: 0.9mm

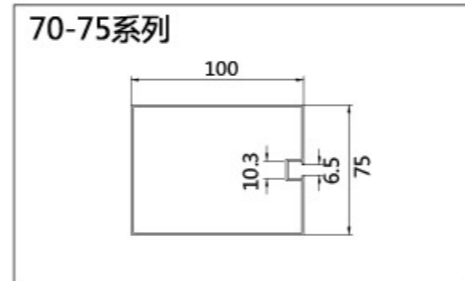

名称: CD-100x75TH
壁厚: 1.1mm

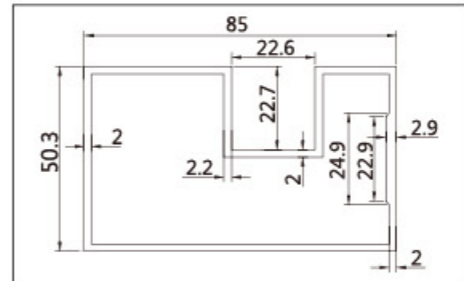

名称: CD-0967
壁厚: 2.0mm

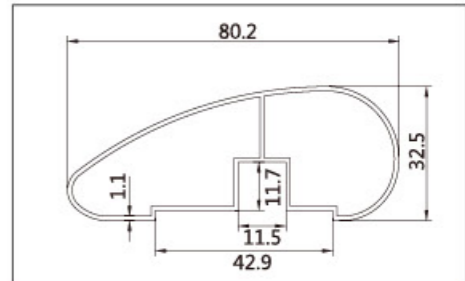

名称: CD-0968
壁厚: 2.0mm

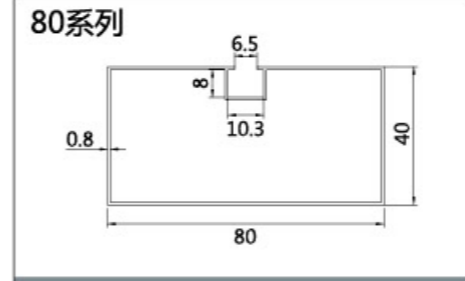

名称: CD-40x80TH
壁厚: 0.8mm

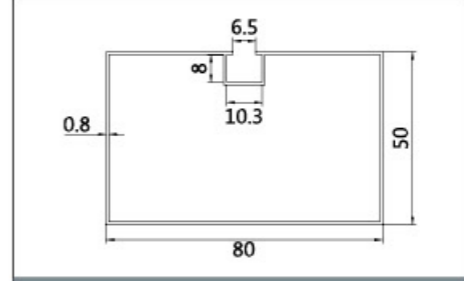

名称: CD-50x80TH
壁厚: 0.8mm

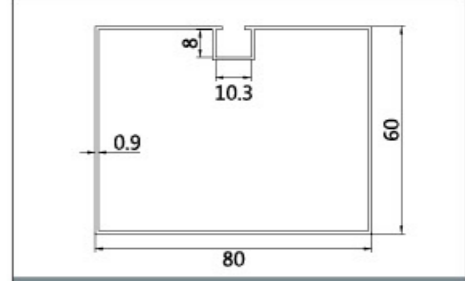

名称: CD-60x80TH
壁厚: 0.9mm

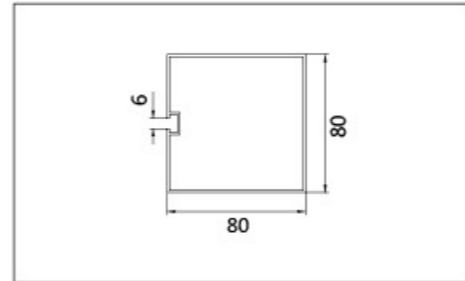

名称: 80x80
壁厚: 1.0 1.3mm

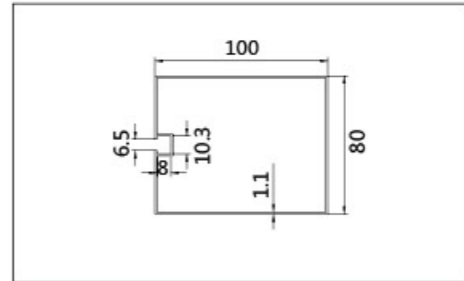

名称: CD-1001
壁厚: 1.1 1.5mm

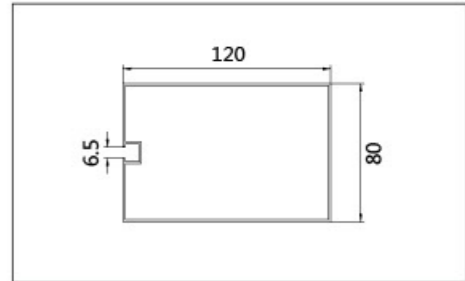

名称: 120x80x1.2TH
壁厚: 1.2 1.4mm

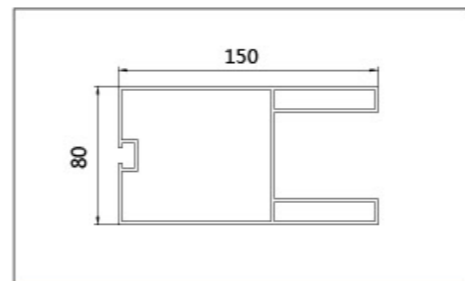

名称: CD-010
壁厚: 1.9mm

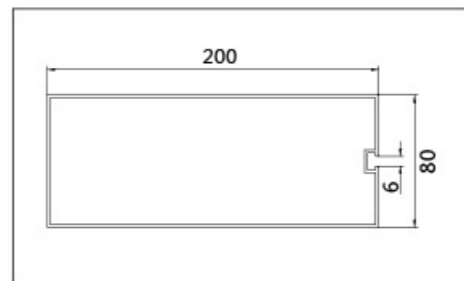

名称: CD-0542
壁厚: 1.8mm

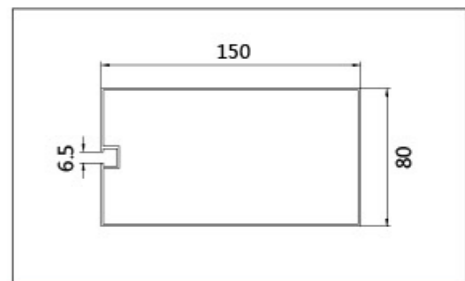

名称: 150x80TH
壁厚: 1.6 1.9mm

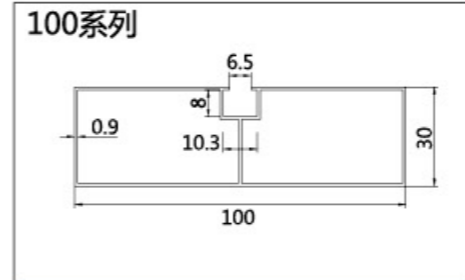

名称: CD-030x100TH
壁厚: 0.9mm

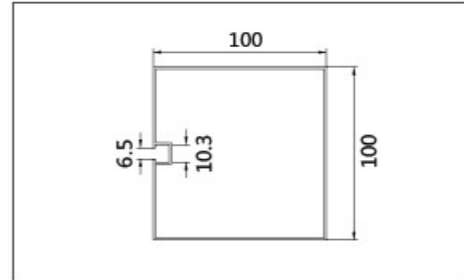

名称: 100x100TH
壁厚: 1.2 1.5 2.0mm

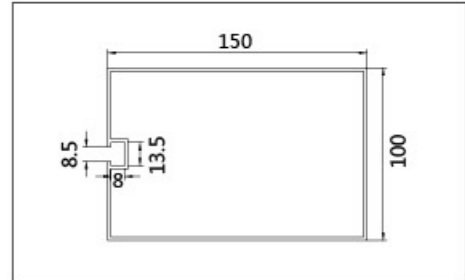

名称: CD-0869
壁厚: 1.9mm

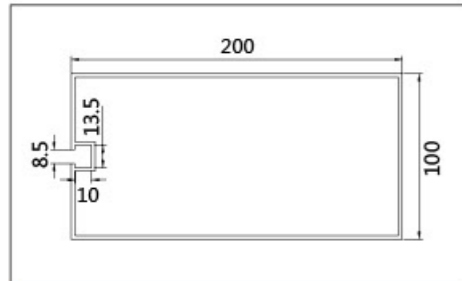

名称: CD-0985
壁厚: 2.2mm

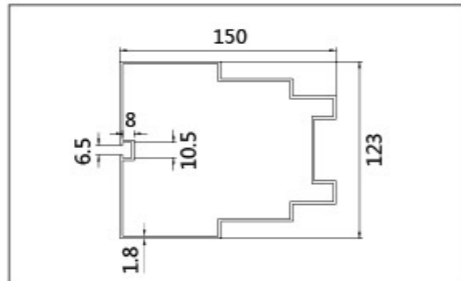

名称: CD-1059
壁厚: 1.8mm

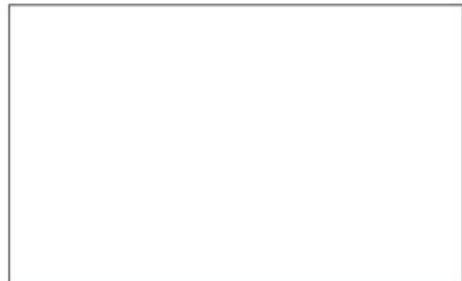

SIX BORDER

series 六边框系列

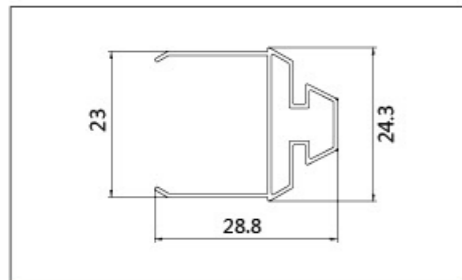

名称: CD-1231
壁厚: 0.6mm

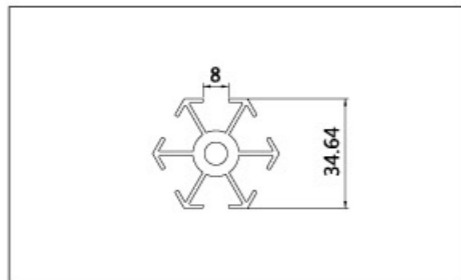

名称: CD-1232
壁厚: 1.2mm

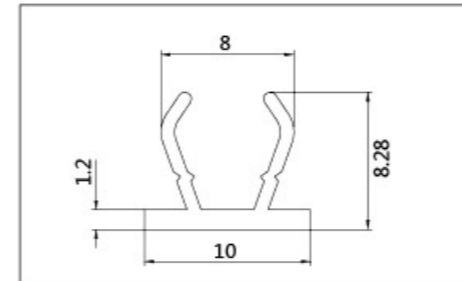
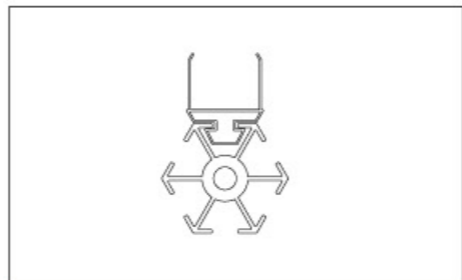

名称: CD-10FG
壁厚: 1.2mm

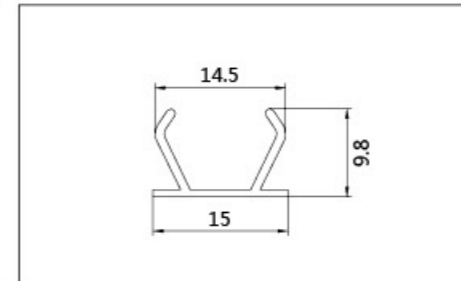

名称: CD-0816
壁厚: 0.8mm

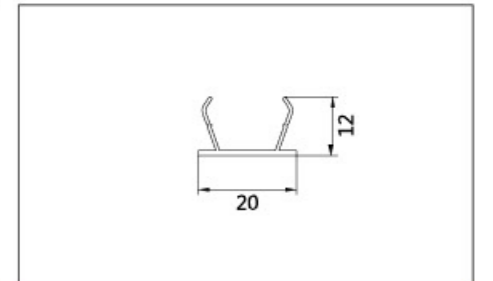

名称: 20 封盖
壁厚: 0.7mm

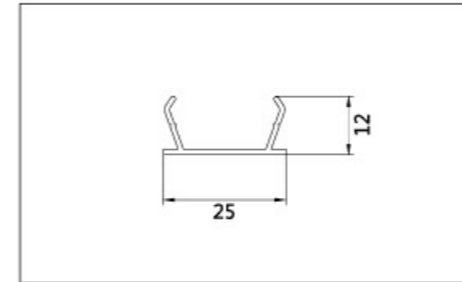

名称: 25 封盖
壁厚: 1.0mm

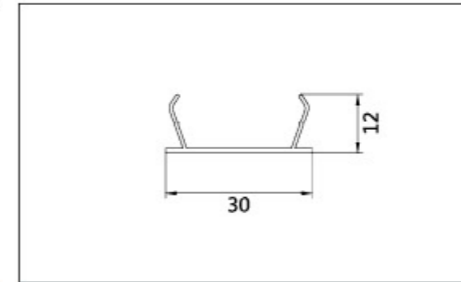

名称: 30 封盖
壁厚: 0.7mm

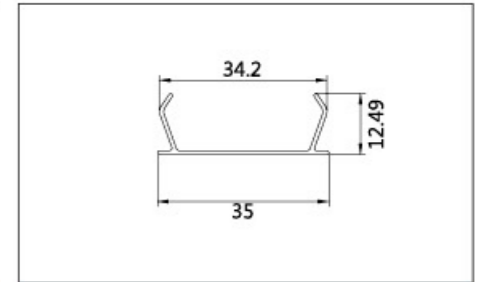

名称: 35 封盖
壁厚: 0.8mm

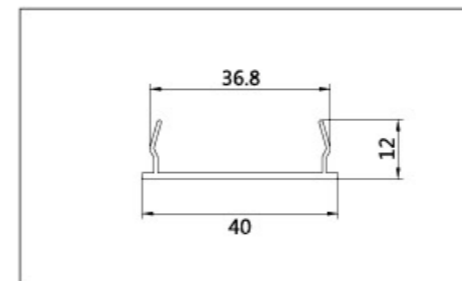

名称: 40 封盖
壁厚: 0.85mm

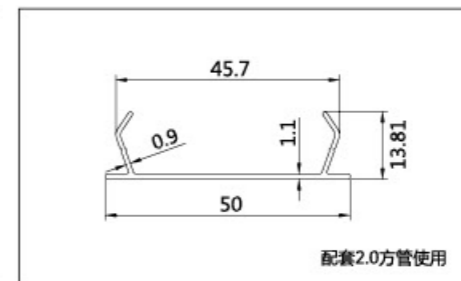

名称: CD-1189
壁厚: 1.1mm

配套2.0方管使用

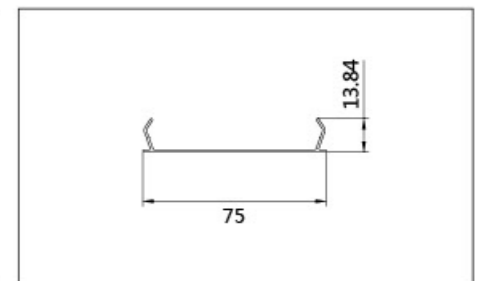

名称: 75 封盖
壁厚: 1.1mm

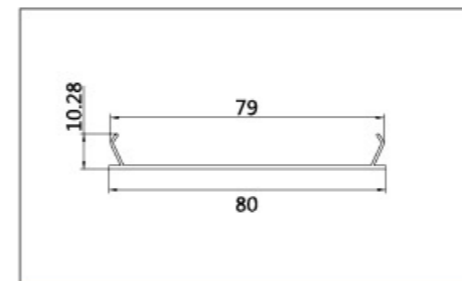

名称: CD-0853
壁厚: 0.8mm

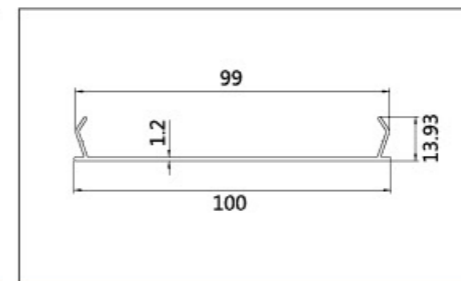

名称: 100 封盖
壁厚: 1.2mm

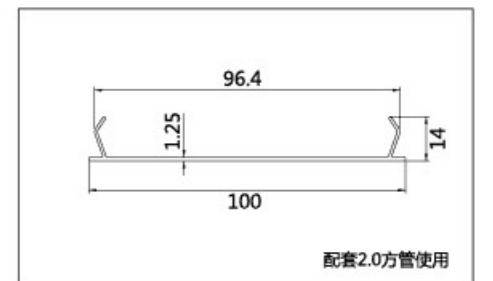

名称: 100FG-G
壁厚: 1.2mm

配套2.0方管使用

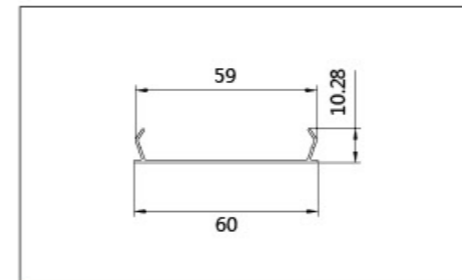

名称: 60 封盖
壁厚: 0.8mm

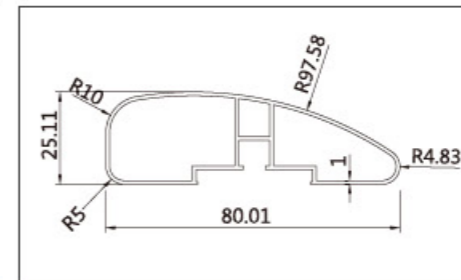

名称: CD-1267
壁厚: 2.0mm

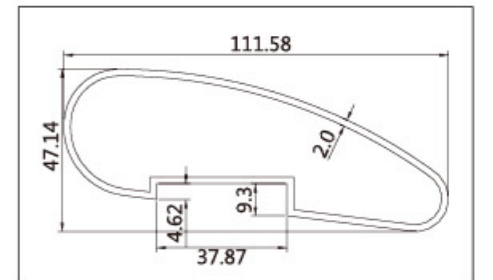

名称: CD-1143
壁厚: 2.0mm

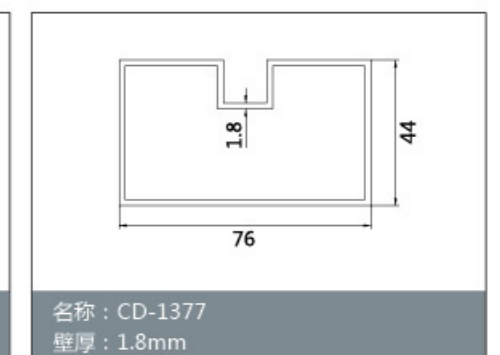
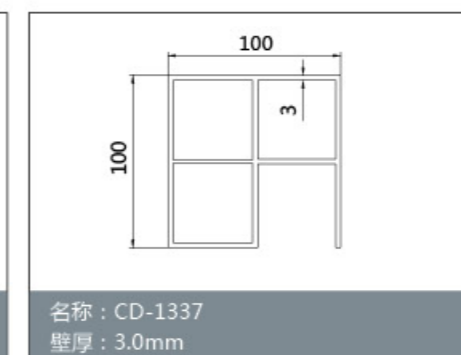
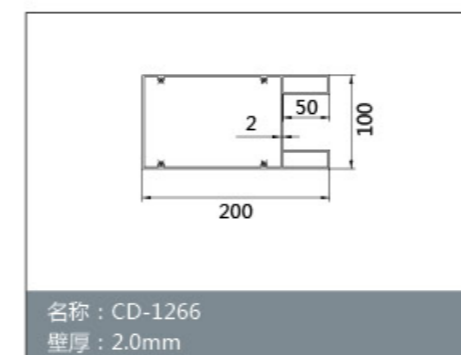
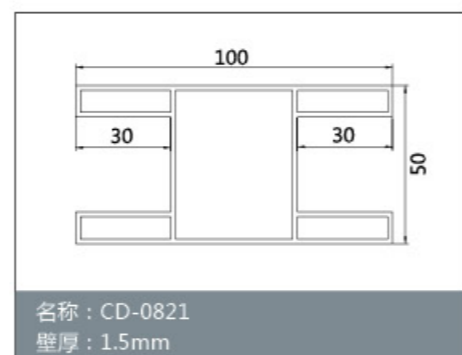
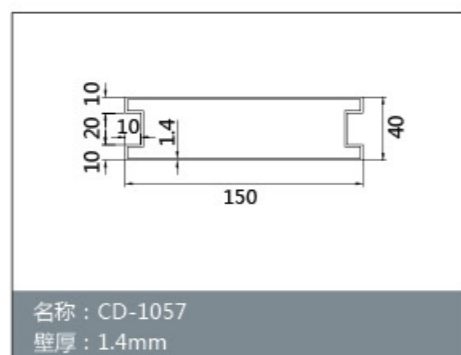
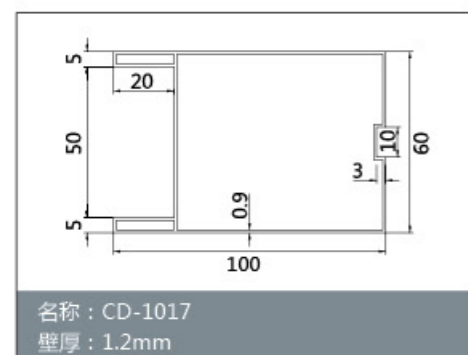
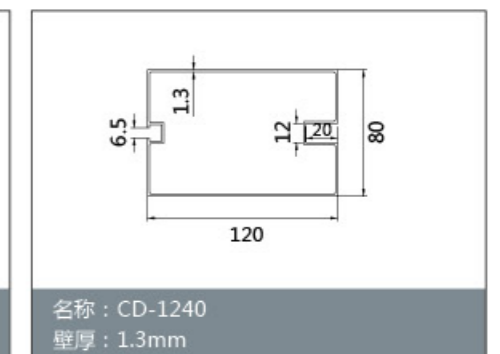
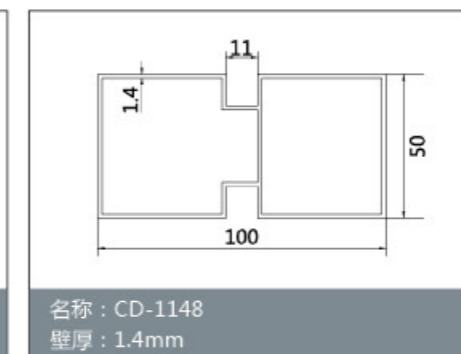
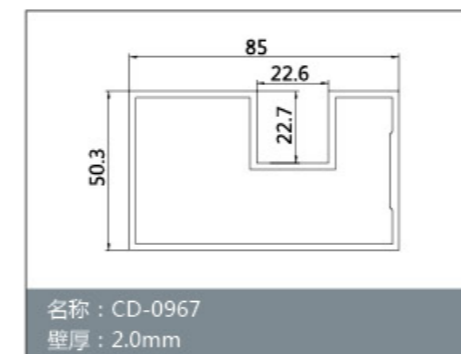
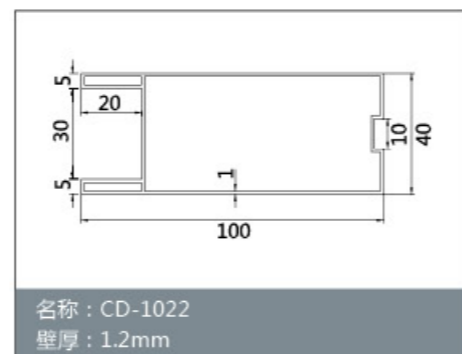
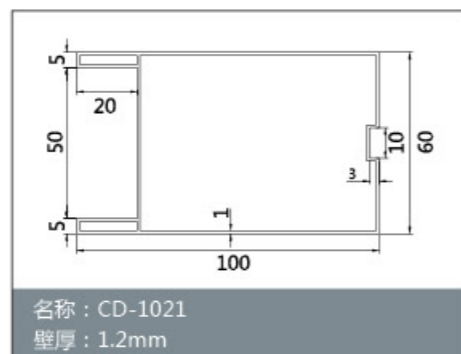
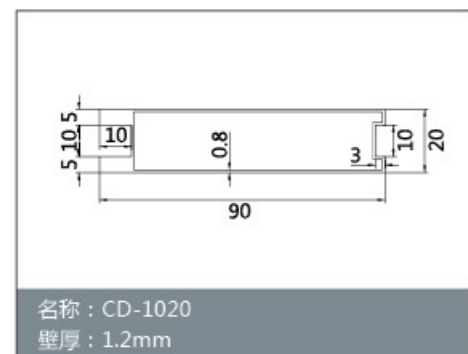
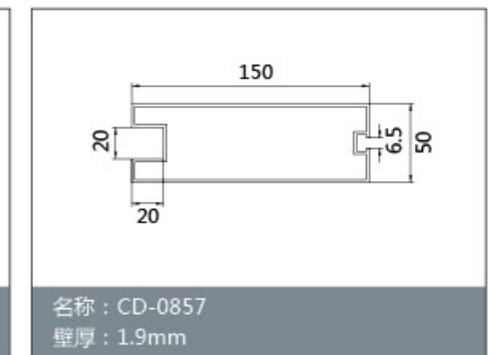
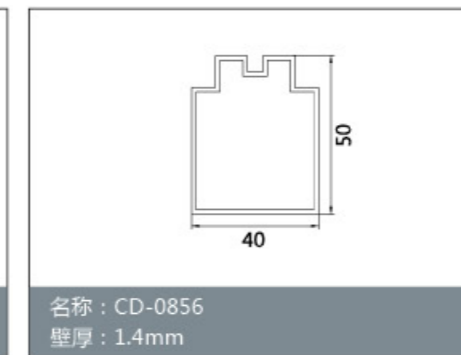
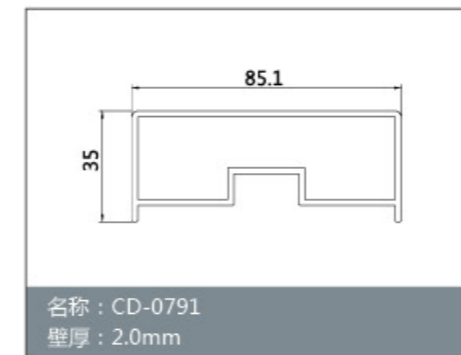
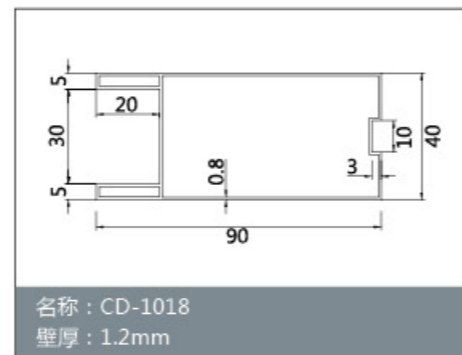
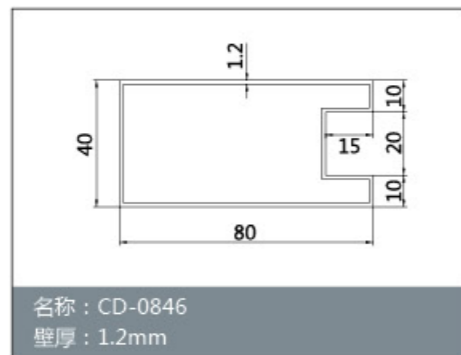
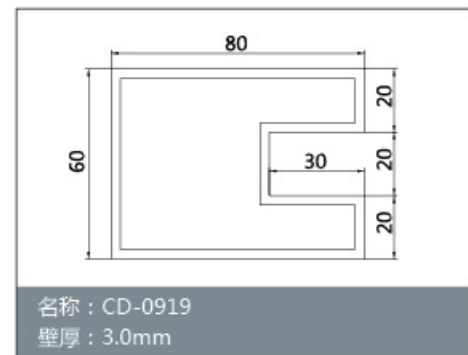
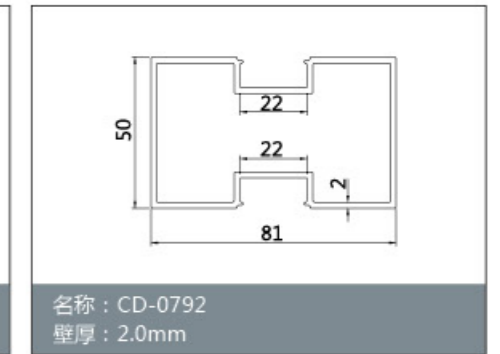
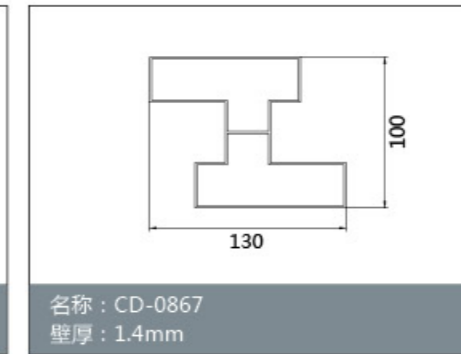
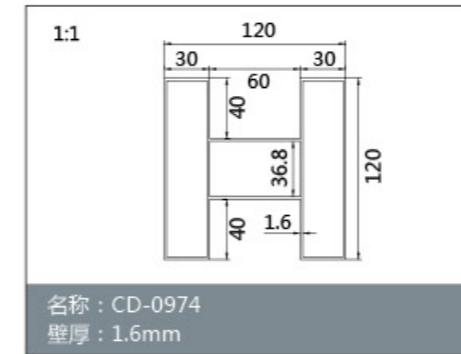
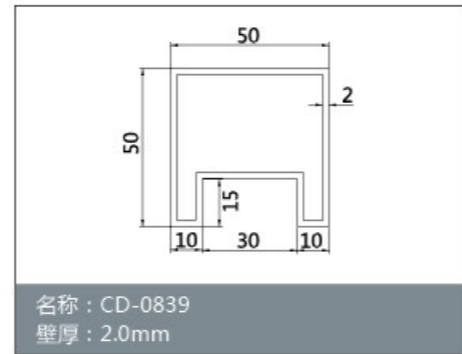
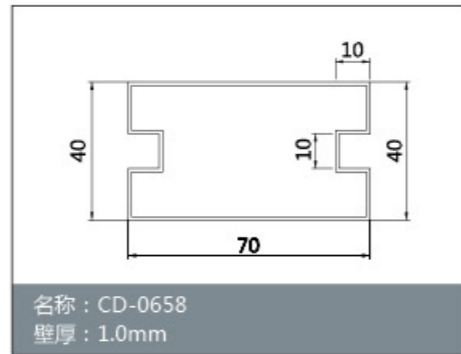
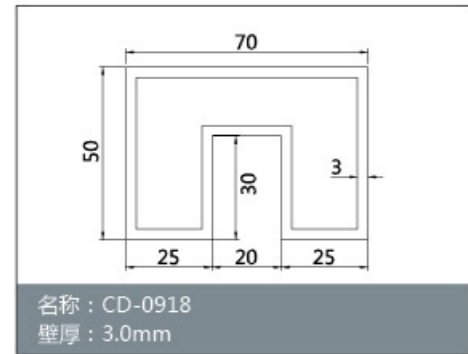
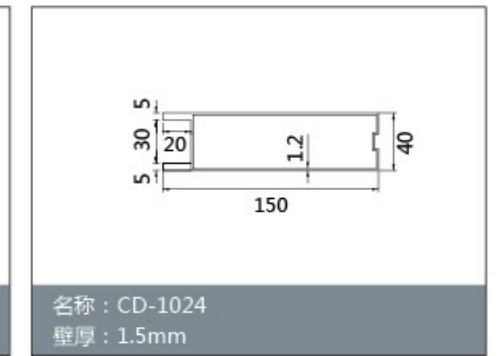
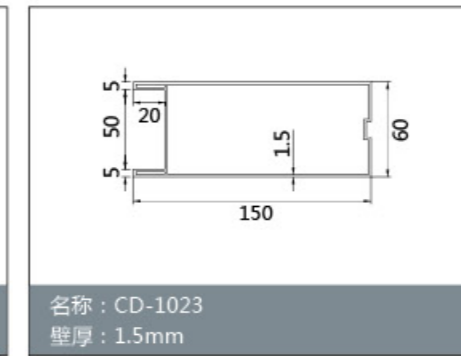
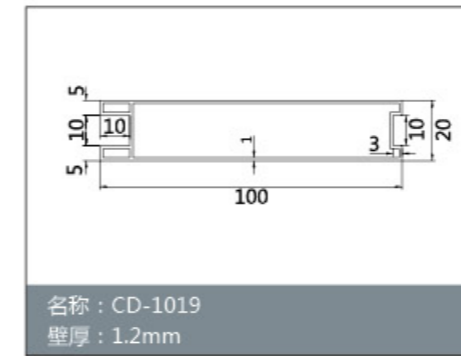
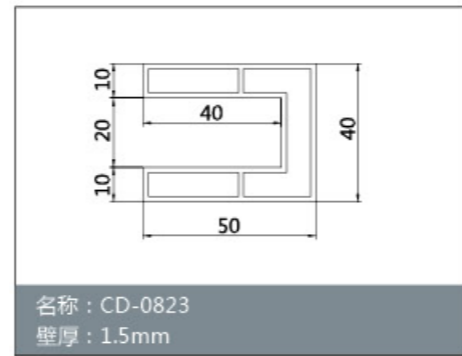
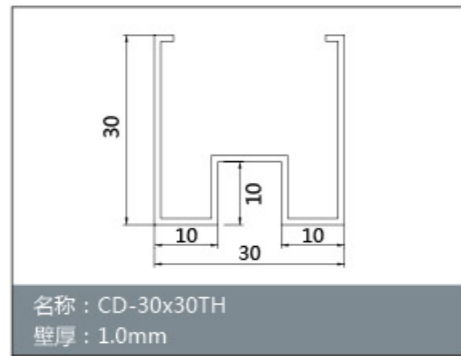
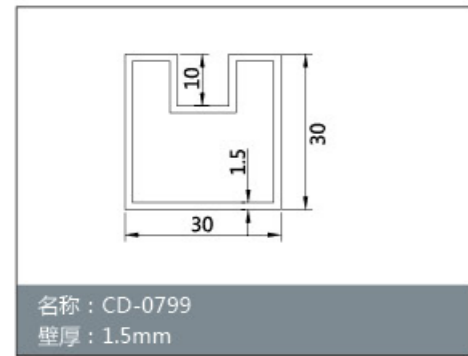

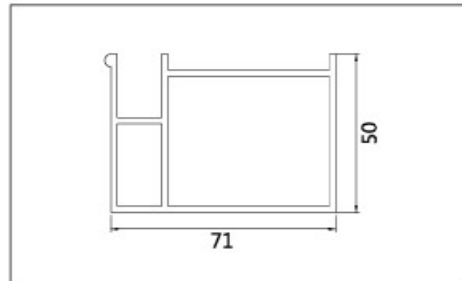

名称: CD-1339
壁厚: 2.0mm

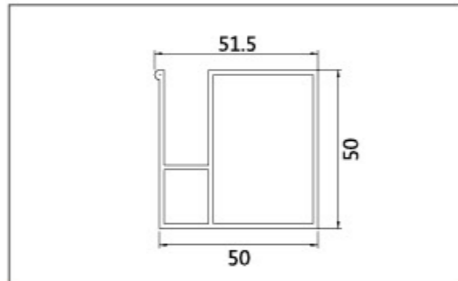

名称: CD-1340
壁厚: 1.5mm

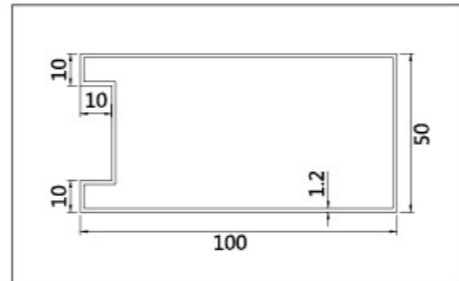

名称: CD-1349
壁厚: 1.2mm

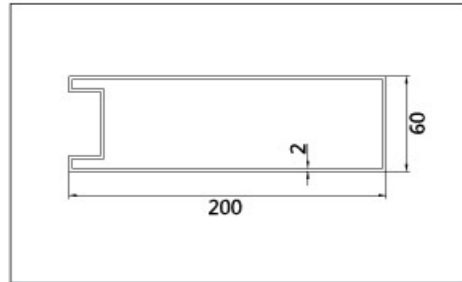

名称: CD-1396
壁厚: 2.0mm

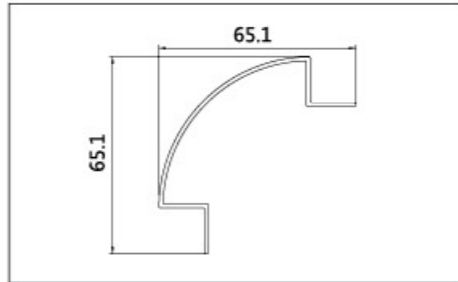

名称: CD-1341
壁厚: 1.4mm

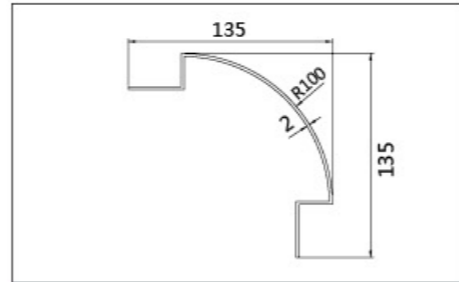

名称: CD-1342
壁厚: 2.0mm

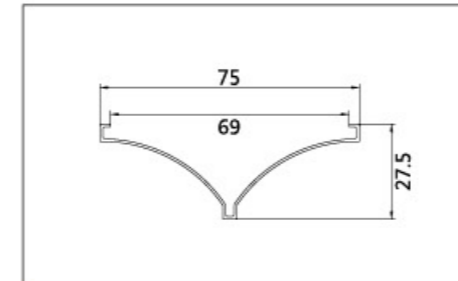

名称: CD-0429
壁厚: 1.5mm

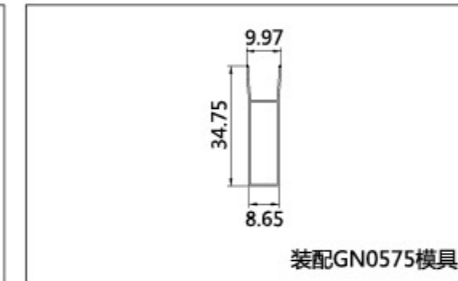

名称: CD-0608
壁厚: 1.0mm

装配GN0575模具

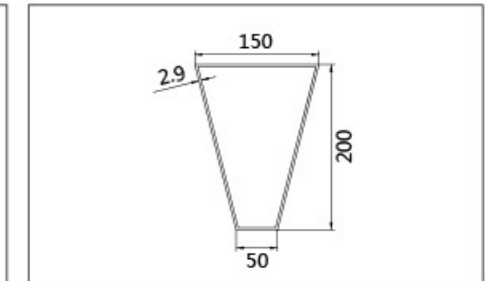

名称: CD-0543
壁厚: 2.9mm



名称: CD-0288
壁厚: 1.0mm



名称: CD-0313
壁厚: 0.7mm



名称: CD-0386
壁厚: 1.2mm

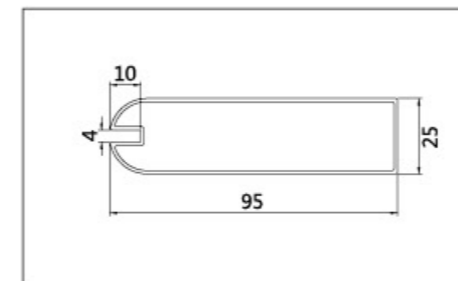

名称: CD-0073
壁厚: 1.1mm

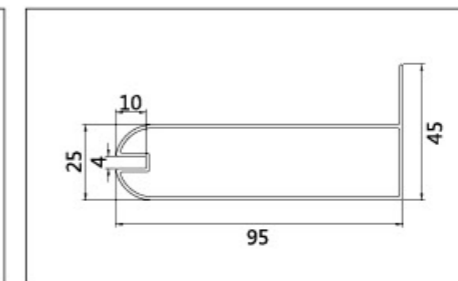

名称: CD-0074
壁厚: 1.1mm

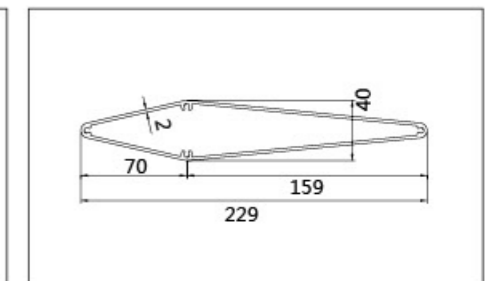

名称: CD-0539
壁厚: 2.0mm

THE ALUMINUM series 铝型材系列

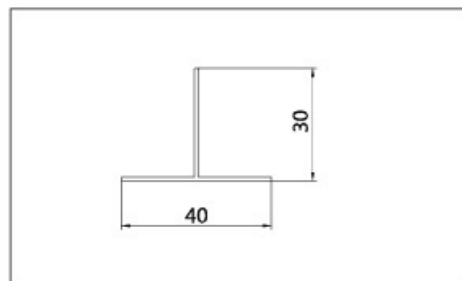

名称: CD-0288
壁厚: 1.0mm

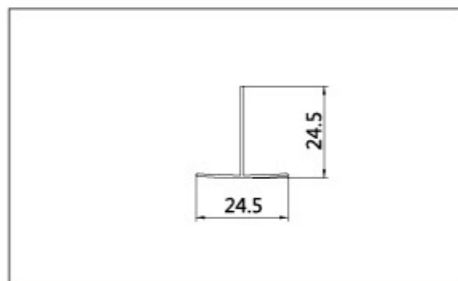

名称: CD-0313
壁厚: 0.7mm

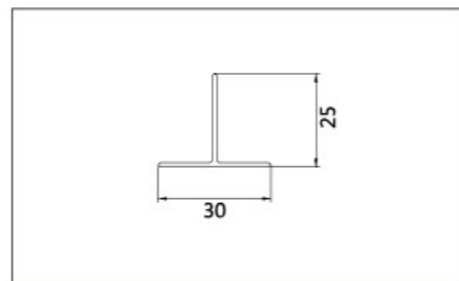

名称: CD-0386
壁厚: 1.2mm

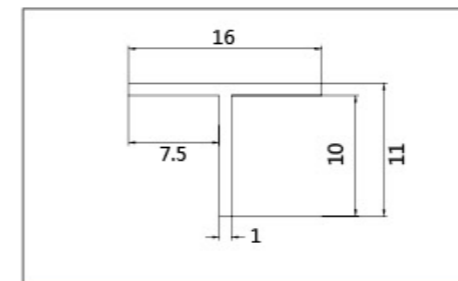

名称: CD-0872
壁厚: 1.0mm

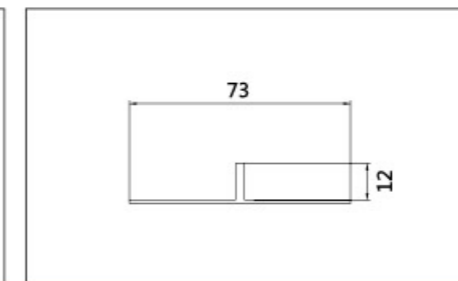

名称: CD-0945
壁厚: 1.2mm

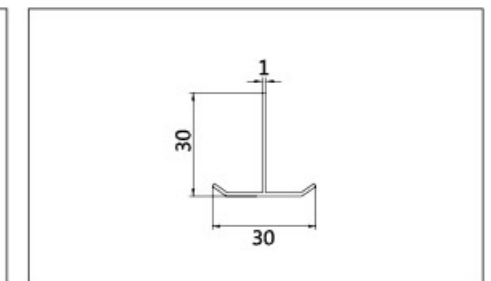

名称: CD-1348
壁厚: 1.0mm

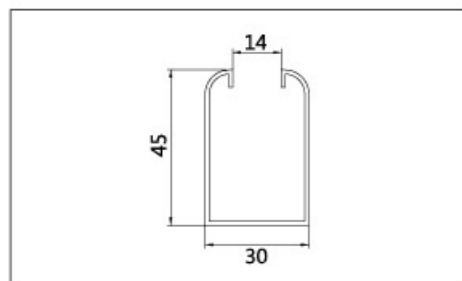

名称: CD-0599
壁厚: 1.2mm

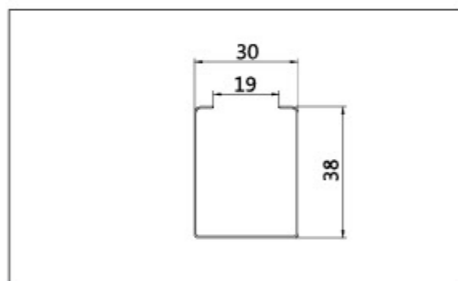

名称: CD-0031
壁厚: 0.46mm

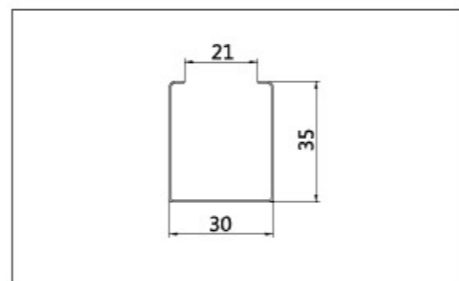

名称: CD-0148
壁厚: 0.49mm

COMPOSITE pipe series 组合管系列

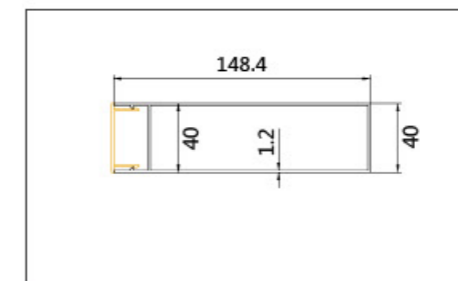

名称: CD-1210
壁厚: 1.3mm

名称: CD-1161
壁厚: 1.2mm

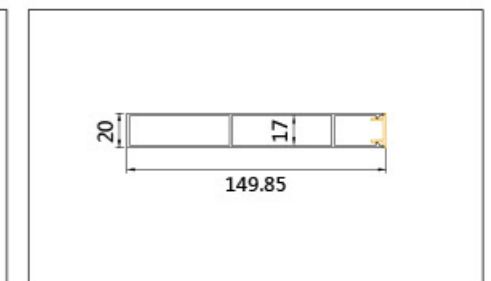

名称: CD-1046
壁厚: 1.45mm

名称: CD-1047
壁厚: 1.45mm

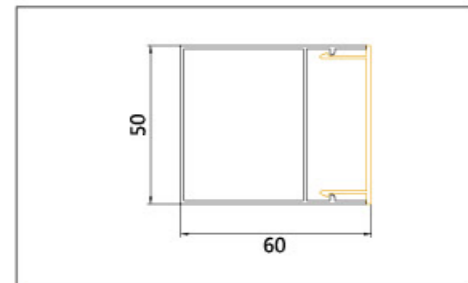

名称: CD-1172 CD-1173
壁厚: 1.0mm 1.2mm

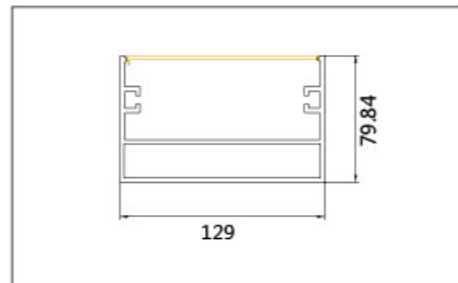

名称: CD-1039 CD-1040
壁厚: 2.5mm 2.5mm

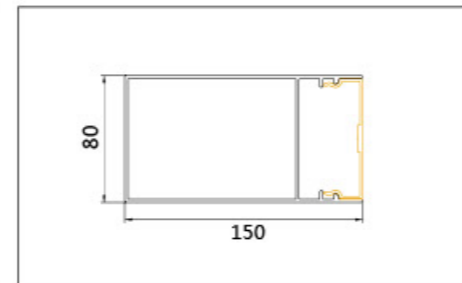

名称: CD-1153 CD-1154
壁厚: 1.9mm 1.4mm

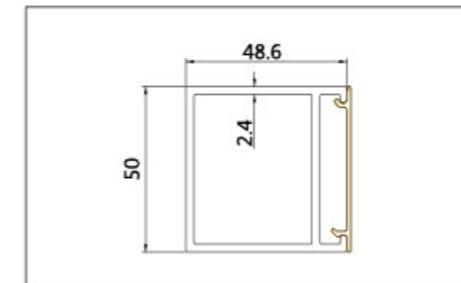

名称: CD-1259 CD-1260
壁厚: 2.4mm 1.2mm

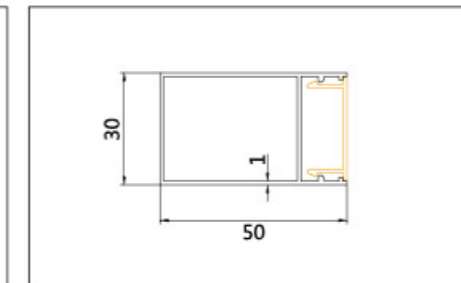

名称: CD-1284 CD-1285
壁厚: 1.0mm 1.0mm

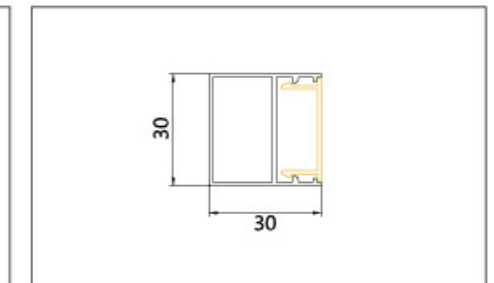

名称: CD-1286 CD-1285
壁厚: 1.0mm 1.0mm

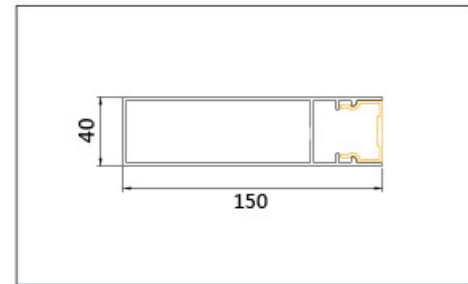

名称: CD-1155 CD-1156
壁厚: 1.9mm 1.4mm

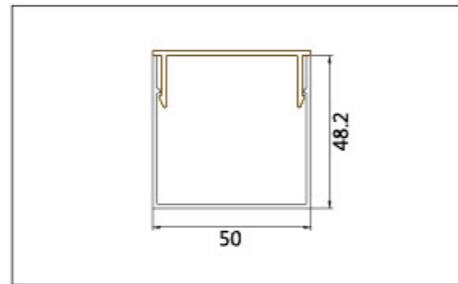

名称: CD-1035 CD-1036
壁厚: 1.42mm 1.42mm

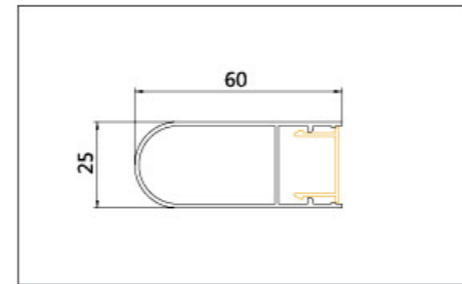

名称: CD-0948 CD-0949
壁厚: 1.2mm 1.0mm

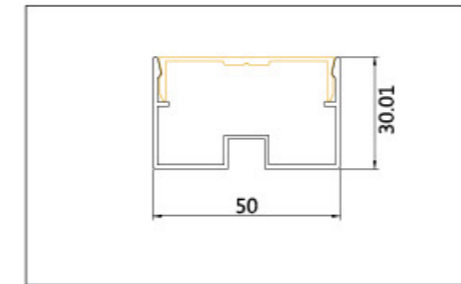

名称: CD-1299 CD-1300
壁厚: 1.2mm 1.2mm

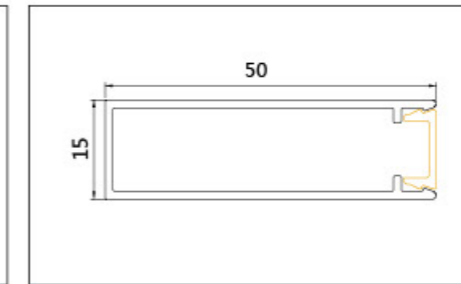

名称: CD-1301 CD-1302
壁厚: 1.2mm 1.2mm

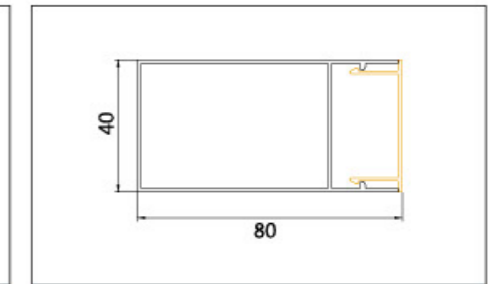

名称: CD-1358 CD-1359
壁厚: 1.1mm 1.1mm

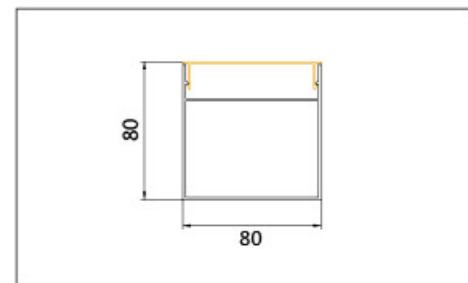

名称: CD-0922 CD-0923
壁厚: 1.45mm 1.45mm

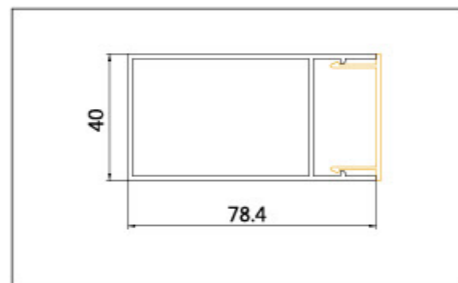

名称: CD-0924 CD-0925
壁厚: 1.45mm 1.45mm

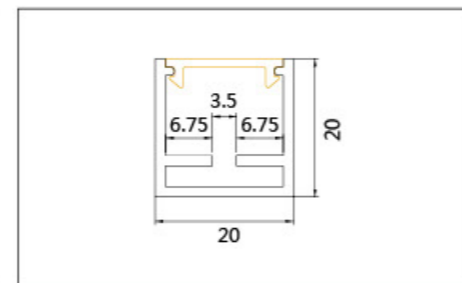

名称: CD-0832 CD-0833
壁厚: 1.5mm 1.2mm

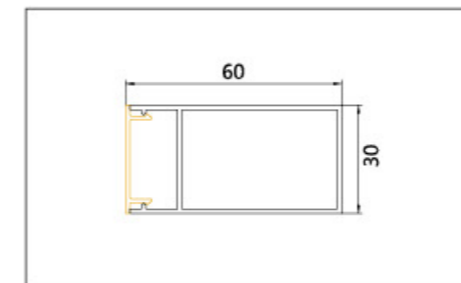

名称: CD-1404 CD-1405
壁厚: 1.2mm 1.2mm

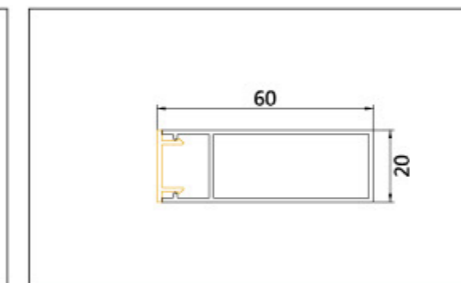

名称: CD-1401 CD-1402
壁厚: 1.2mm 1.2mm

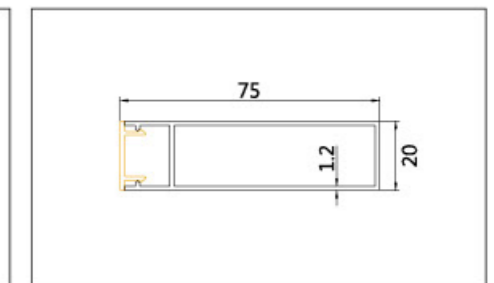

名称: CD-1403 CD-1402
壁厚: 1.2mm 1.2mm

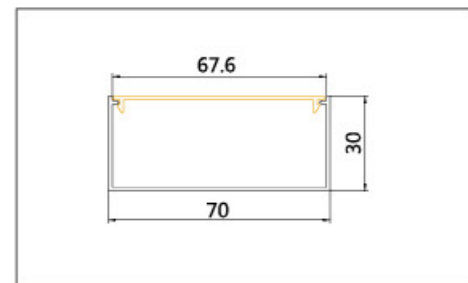

名称: CD-0718 CD-0719
壁厚: 1.2mm 1.2mm

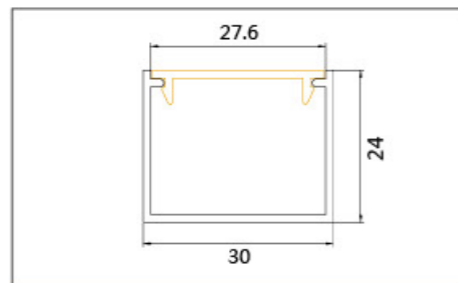

名称: CD-0720 CD-0721
壁厚: 1.2mm 1.2mm

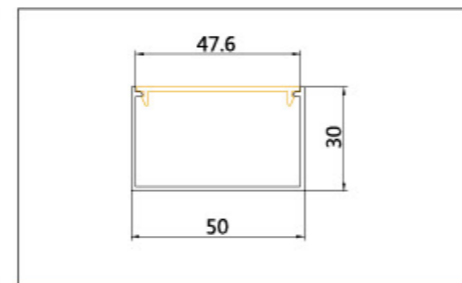

名称: CD-0722 CD-0723
壁厚: 1.2mm 1.2mm

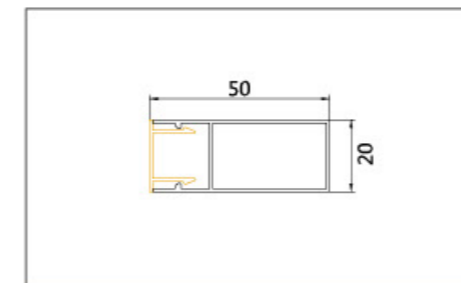

名称: CD-1372 CD-1373
壁厚: 0.9mm 0.9mm

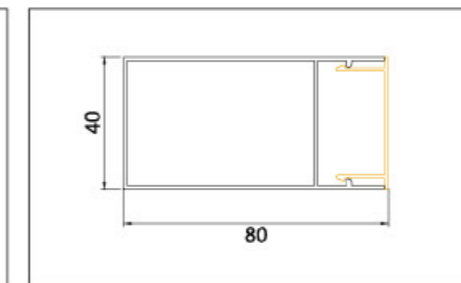

名称: CD-1358 CD-1359
壁厚: 1.1mm 1.1mm

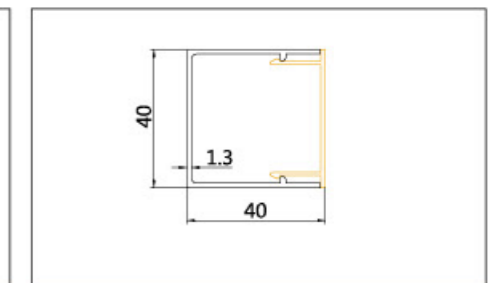

名称: CD-1209 CD-1210
壁厚: 1.3mm 1.3mm

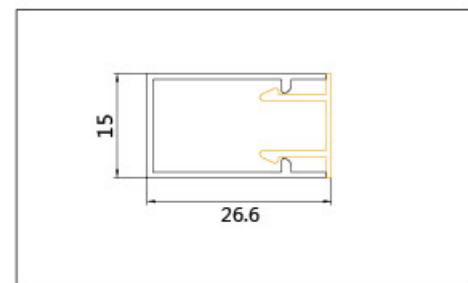

名称: CD-1195 CD-1196
壁厚: 0.8mm 0.8mm

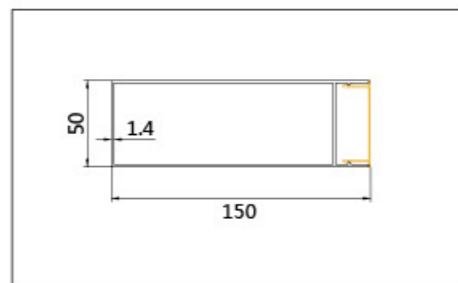

名称: CD-1241 CD-1239
壁厚: 1.4mm 0.95mm

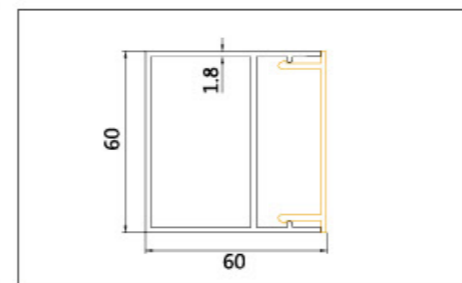

名称: CD-1249 CD-1250
壁厚: 1.8mm 1.8mm

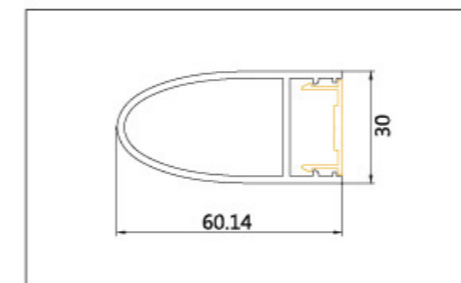

名称: CD-1296 CD-1295
壁厚: 1.9mm 1.0mm

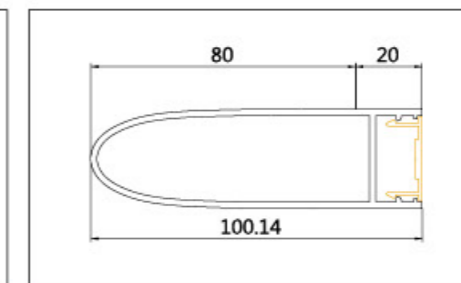

名称: CD-1294 CD-1295
壁厚: 1.9mm 1.0mm

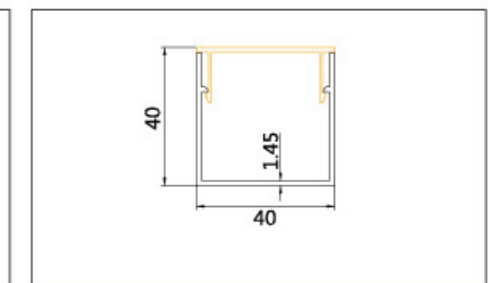

名称: CD-0942 CD-1210
壁厚: 1.45mm 1.3mm

MOULD SPECIFICATION

Of square pipe 方管模具规格 ▼

序号	长 (mm)	宽 (mm)	厚度 (mm)	
1	10	10	0.7	
2			1	
3	12	10	0.7	
4	15	10	1.0	
5	15	15	1	
6			1.2	
7	16	16	1.2	
8	19	19	1.2	
9			2.0	
10	20	10	0.8	
11			1	
12			1.5	
13	20	15	1	
14			1.2	
15			1.6	
16	20	20	0.55	
17			0.7	
18			0.8	
19			0.9	
20			1	
21			1.2	
22			1.5	
23			1.8	
24			2	
25			3	
26	20	25	0.9	
27			1	
28			1.6	
29			2	
30	25	10	1.0	
31			1.2	
32		15	1.0	
33			1.2	
34				1.8
35		25	25	0.5
36				0.65
37				0.8
38				1
39				1.2
40	1.4			
41	1.5			
42	1.8			
45	2			
46	3			
47	30	15	0.84	
48			1	
49			1.2	
50			1.5	
51				2.05
52		20	0.5	
53			0.7	
54			0.85	

序号	长 (mm)	宽 (mm)	厚度 (mm)
55	30	30	1
56			1.2
57			1.5
58			1.8
59			2.9
60			30
61	1		
62	1.2		
63	1.4		
64	0.8		
65	30	30	1
66			1.1
67			1.2
68			1.4
69			2
70			3
71			32
72			1.4
73	35	35	1
74			1.5
75			2
76	38	20	1.0
77			0.6
78		0.8	
79		1	
80		25	1.2
81			1.4
82			1.8
83		38	2
84			3
85			1
86	38	1.2	
87		1.4	
88		2	
89		3	
90	40	10	1
91			1.2
92			0.9
93			1.4
94			2.0
95	20	0.8	
96		1	
97		1.2	
98		1.5	
99		1.85	
100			2
101	25	1	
102		1.6	
103		2.06	
104	30	0.8	
105		1	
106		1.2	

序号	长 (mm)	宽 (mm)	厚度 (mm)		
107	40	30	1.5		
108			1.8		
109			2		
110			3		
111			40	40	0.6
112	0.8				
113	1				
114	1.2				
115	1.5				
116	1.8				
117	2				
118	2.5				
119	3				
120	3.5				
121	4.9				
122	45	45	1.2		
123			1.5		
124			1.8		
125	50	10	3		
126			1		
127			1.2		
128	50	15	1.0		
129			1.15		
130			1.4		
131	50	20	0.7		
132			1		
133			1.2		
134			1.4		
135			3		
136			50	25	0.6
137					0.8
138	1				
139	1.2				
140	1.5				
141	2				
142	2.9				
143	3				
144	50	30	0.8		
145			1		
146			1.2		
147			1.5		
148			1.9		
149			2		
150			2.4		
151			3		
152			50	40	0.8
153					1
154	1.2				
155	1.5				
156	1.8				
157	2				
158	2.35				

序号	长 (mm)	宽 (mm)	厚度 (mm)		
159	50	50	40		
160			0.8		
161			1		
162			1.1		
163			1.2		
164			1.4		
165			1.8		
166			2		
167			2.5		
168			3		
169	4				
170	5				
171	60	20	1		
172			1.2		
173			1.3		
174			1.5		
175			1.8		
176	60	25	0.9		
177			1		
178			1.2		
179	3				
180	60	30	0.8		
181			1		
182			1.2		
183			1.5		
184			2		
185			3		
186			0.6		
187			0.8		
188			1		
189			1.2		
190	1.4				
191	2				
192	3				
193	60	40	1		
194			1.2		
195			1.5		
196			1.8		
197			1		
198	60	60	1.2		
199			1.5		
200			1.8		
201			2		
202			2.5		
203			3		
204			3.5		
205			70	20	0.8
206					1
207					2
208	0.95				
209	1.2				
210	25	2			

MOULD SPECIFICATION

Of square pipe 方管模具规格 ▼

序号	长 (mm)	宽 (mm)	厚度 (mm)		
211	70	30	1		
212			1.2		
213			1.4		
214			2		
215	70	40	1.8		
216		50	1.0		
217			1.3		
218	70	50	1.8		
219			1.5		
220			2		
221	75	30	1.5		
222		50	1.2		
223			1.5		
224			1.8		
225	76	25	0.6		
226			0.8		
227			1		
228			1.2		
229			1.5		
230			1.8		
231			2		
232			3		
233			76	44	0.6
234					0.8
235	1				
236	1.2				
237	1.5				
238	1.8				
239	2				
240	3				
241	76	76			1.2
242					1.5
243			2		
244			3		
245	80	10	1.2		
246	80	20	0.8		
247			1		
248			1.2		
249			1.8		
250			2		
251		25	0.8		
252			1		
253			1.2		
254			1.5		
255			2		
256	80	30	3		
257			0.8		
258			1		
259			1.2		
260			1.4		
261			1.5		
262			2		

序号	长 (mm)	宽 (mm)	厚度 (mm)		
263	80	30	2.7		
264	80	40	0.8		
265			1		
266			1.2		
267			1.4		
268			1.8		
269			2		
270			3		
271			80	44	0.8
272					0.9
273					1
274	1.2				
275	1.4				
276	1.8				
277	2				
278	3				
279	80	50			0.8
280					1
281			1.2		
282			1.4		
283			1.8		
284			2		
285			3.0		
286			80	60	1.2
287					1.45
288					1.8
289	2				
290	3				
291	2.5				
292	80	80			1
293					1.2
294					1.5
295					1.8
296			2		
297			3		
298			15		
299			90	20	0.85
300				1.5	
301				25	0.8
302	90	25	1		
303			1.2		
304		30	0.9		
305		50	1		
306		90	1.4		
307		90	1.6		
308		91	22	0.95	
309	100	10	0.9		
310			1		
311			1.2		
312		15	1		
313			2		
314			18	2	

序号	长 (mm)	宽 (mm)	厚度 (mm)		
315	100	20	0.8		
316			1.2		
317			1.8		
318		25	0.8		
319			0.9		
320			1		
321			1.2		
322			1.5		
323			1.9		
324			2		
325	100	30	3		
326			0.8		
327			1		
328			1.2		
329			1.5		
330			1.8		
331			2		
332			3		
333			100	40	0.9
334					1
335	1.4				
336	1.8				
337	2				
338	3				
339	100	44			0.8
340			0.94		
341			1		
342			1.2		
343			1.5		
344			1.8		
345			2		
346			2.5		
347			3		
348			100	60	0.8
349	0.9				
350	1				
351	1.2				
352	1.4				
353	1.5				
354	1.8				
355	2				
356	2.5				
357	3				
358	4				
359	100	70	1		
360			1.2		
361			1.5		
362			1.8		
363			2		
364			3		
365			100	80	1.25
366			100	80	1.3

序号	长 (mm)	宽 (mm)	厚度 (mm)		
367	100	80	1.8		
368	100	100	2.8		
369			1.3		
370			1.5		
371			1.8		
372			2		
373			2.5		
374			3		
375			4		
376			5		
377			120	20	0.95
378	1.5				
379	25	1.2			
380		1.5			
381		1.8			
382	30	2			
383		1.2			
384		1.9			
385		1			
386		1.2			
387	120	40	1.5		
388			2		
389			3		
390	120	50	1.2		
391			1.5		
392			1.8		
393			2		
394			3		
395			120	60	1.2
396					1.5
397					1.8
398					2
399					2.4
400	3				
401	120	70		3.0	
402				1.2	
403		80		1.5	
404				1.8	
405			2		
406		100	3		
407			1.5		
408			2		
409			2.9		
410			2		
411	120	120	3		
412			5		
413			3.0		
414	125	50	1.4		
415		80	2		
416			2.5		
417	130	130	3		
418			4.5		

